

Cuadernillo De Repaso

2º



APRENDIZAJE ESPERADO: Reconoce la existencia de otras lenguas en su comunidad, además de su lengua materna, e indaga sobre su uso.

Explorando

 Utiliza el recortable 1 para que pegues aquí la historia del origen de los tarahumaras.

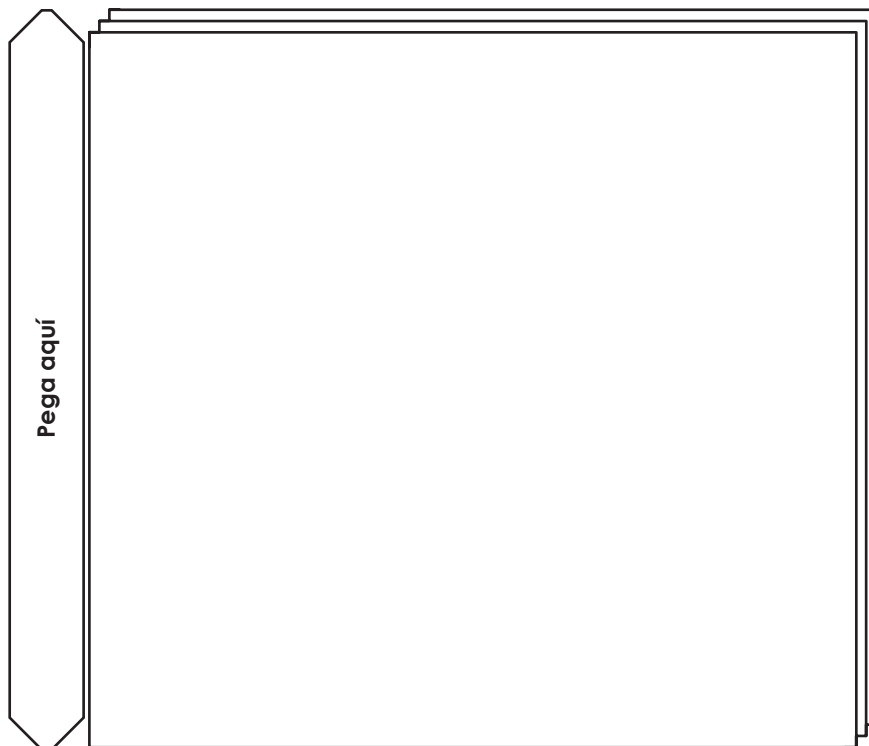

 Utiliza las imágenes del recortable 1 para que las pegues según corresponda.

Rayénari	Mechá
Muki	Ralámuli

Arma y juega

 Juega con la televisión siguiendo las instrucciones. Utiliza el recortable 2.

Instrucciones:

1. Recorta la televisión y pégala en cartulina.
2. Recorta y ordena las imágenes como fueron sucediendo en la historia.
3. Pégalas por las pestañas que tienen a los lados.
4. Recorta las líneas de la televisión por la línea punteada.
5. Pasa la tira de imágenes por la televisión.
6. Utiliza este ejercicio para narrar tu propia versión de la historia.

¡A divertirse!

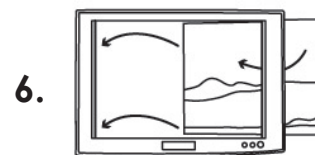
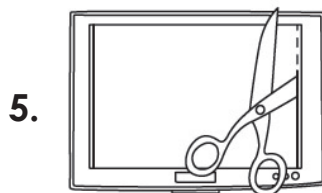
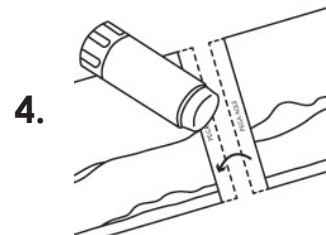
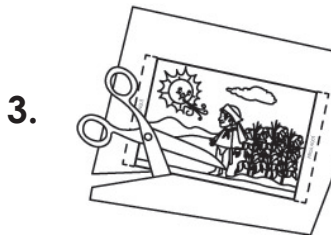
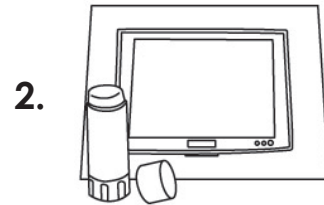
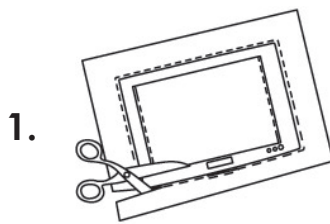

Acomodando

A Ordena las palabras de cada rama del árbol para que puedas escribir 3 oraciones de los tarahumaras.

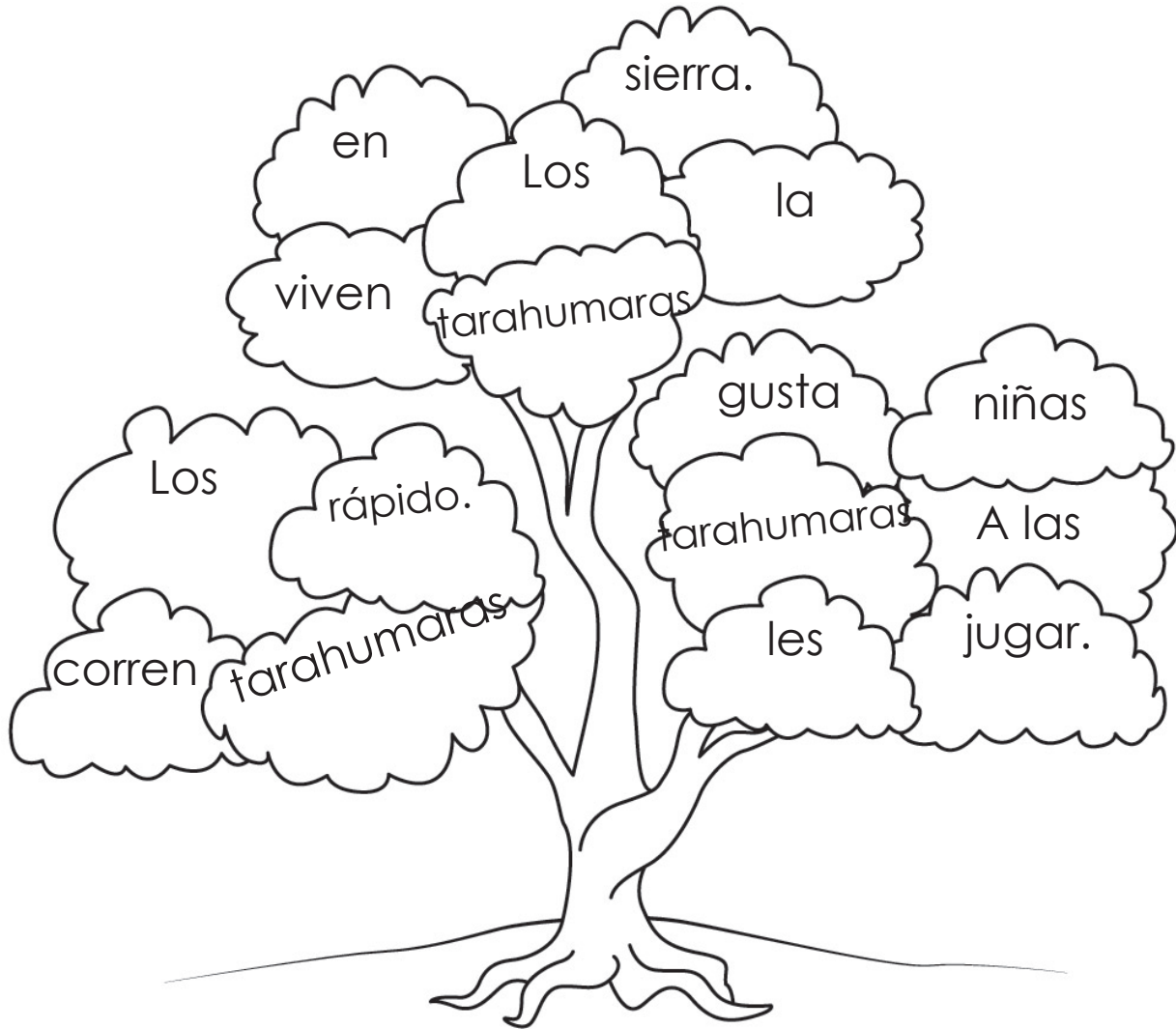

1. _____

2. _____

3. _____

Armando oraciones



Utiliza el recortable 3 y separa las oraciones de forma correcta, pégalas según corresponda.



1. _____
_____.



2. _____.



3. _____
_____.

Conociendo

En Chihuahua utilizamos palabras que provienen de otras lenguas.

 Utiliza el recortable 4 y pega las imágenes donde correspondan.

 Puedes investigar en internet o preguntarle a tus papás.

Okey

Inglés



Kuira

Ralámuli



Hello

Inglés

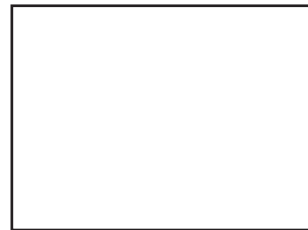

Kinder

Inglés

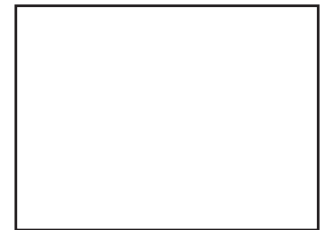

Aguacatl

Náhuatl



Chictli

Náhuatl



Nateterabá

Ralámuli



Xocoatl

Náhuatl



Jugando y aprendiendo

-  Juega al memorama de palabras de origen indígena con el recortable 5.
-  Colorea la imagen.

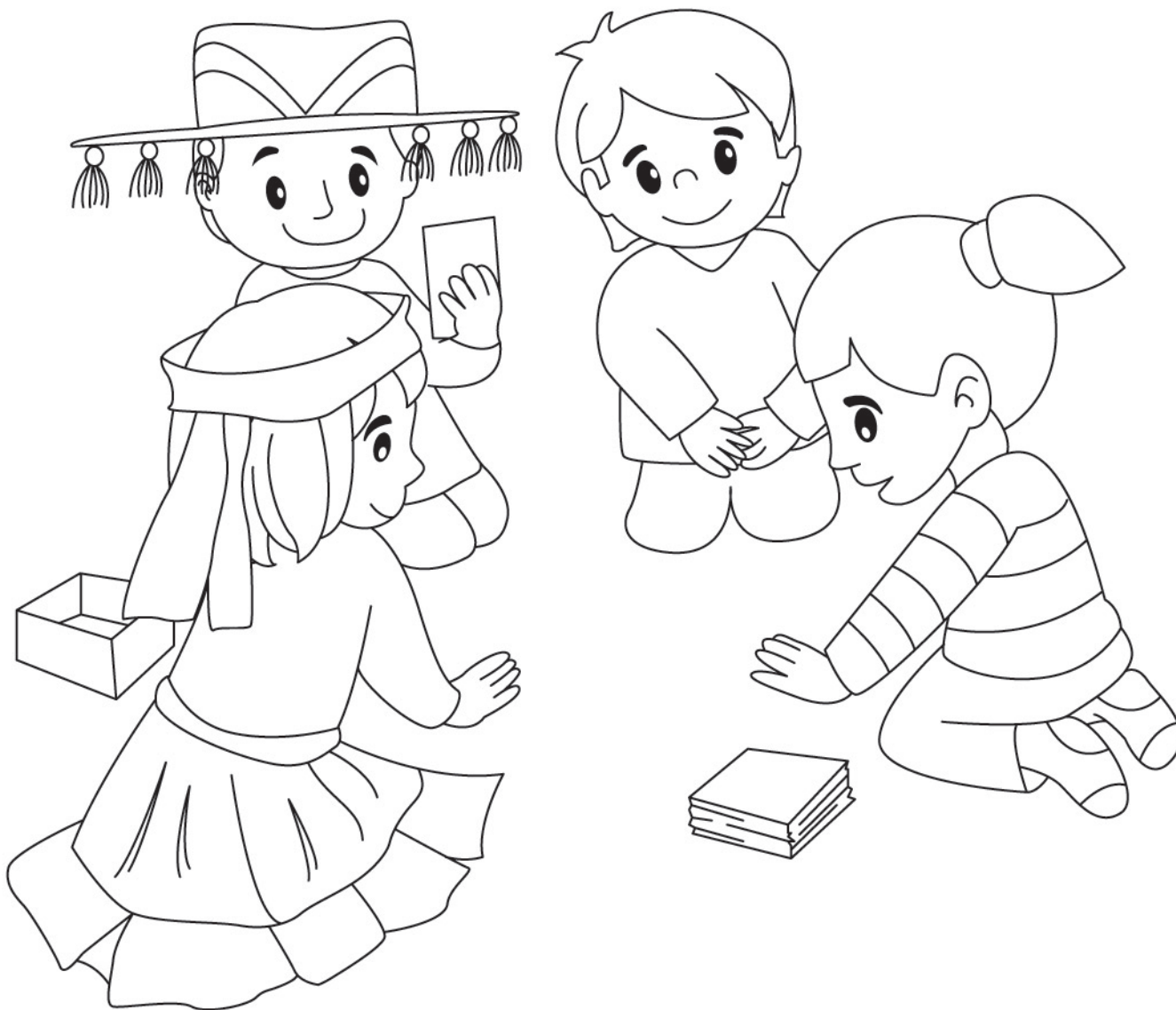







¿Por qué es importante apreciar y respetar todas las lenguas maternas?

APRENDIZAJE ESPERADO: Explora documentos como el acta de nacimiento y la cartilla de vacunación para reflexionar sobre la información personal que contienen.

Documento de identidad

A  **Completa la información que falta en el acta de nacimiento, pide ayuda a tus papás.**

Folio de Impresión 00000000 		Identificador Electrónico 0400200012016002965		
<h3>Estados Unidos Mexicanos</h3> <h3>Acta de Nacimiento</h3>				
Datos de la Personas Registrada				
Nombre(s)	Primer Apellido	Segundo Apellido		
Sexo	Fecha de Nacimiento	Lugar de Nacimiento		
Datos de Filiación de la Persona Registrada				
Nombre(s)	Primer Apellido	Segundo Apellido	Nacionalidad	CURP
Nombre(s)	Primer Apellido	Segundo Apellido	Nacionalidad	CURP
Anotaciones Marginales:		Certificación:		
			Firma Electrónica Avanzada  Licda. Inés Aurora Martínez Bernal Directora General de Registro Civil	
104002000120008033570 		16 Código QR 		
El contenido de esta acta puede ser verificado en la siguiente página web: www.gob.mx/validar capturando el identificador Electrónico. Para su consulta en dispositivos móviles, descarga una aplicación para lectura de Código QR.				

Investigando

¿En cuál de las siguientes instituciones es necesario presentar nuestra acta de nacimiento?

A Utiliza el recortable 6 y escribe en cada imagen para qué necesitamos el acta de nacimiento.

Pega aquí	

Pega aquí	

Pega aquí	

Me cuido

 Utiliza el recortable 7 y arma tu cartilla de vacunación.

 Escribe los datos que faltan con ayuda de tus papás.

Pega aquí	
-----------	--

Utilizamos la cartilla de vacunación para:

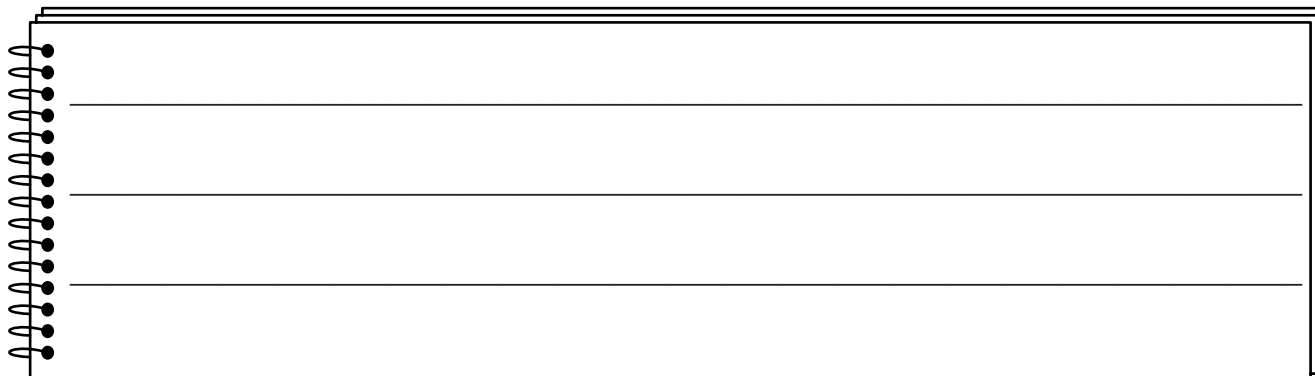

A graphic of a spiral notebook with three horizontal lines for writing.

APRENDIZAJE ESPERADO: Escribe textos sencillos para explicar un procedimiento social sobre el que ha indagado.

Al aire libre

 Con el recortable 8 utiliza los dibujos para completar la imagen.

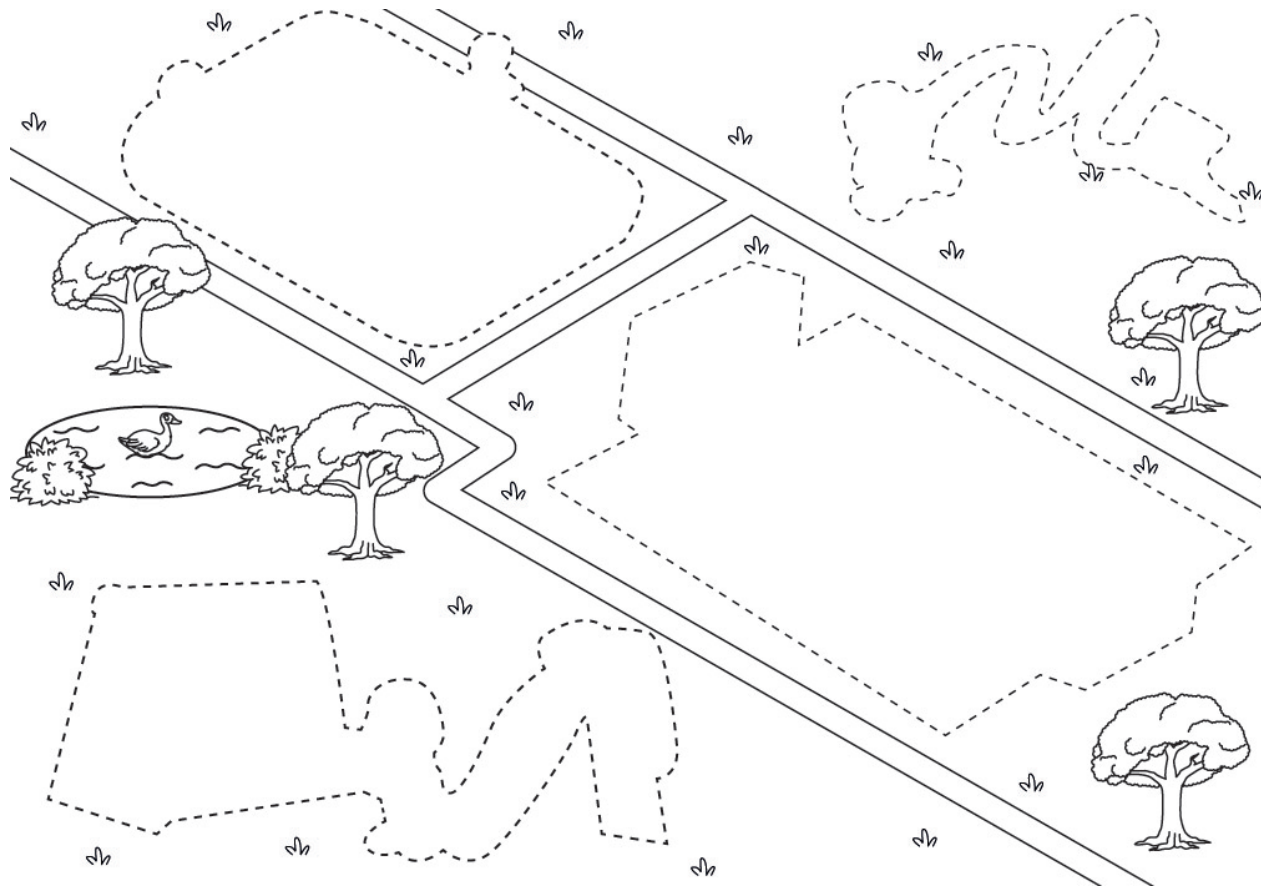

 Escribe que están realizando los niños en esta imagen.



APRENDIZAJE ESPERADO: Selecciona una obra de teatro infantil breve para representarla con títeres.

Personajes

A Describe los personajes de la obra de teatro *Caperucita roja*.

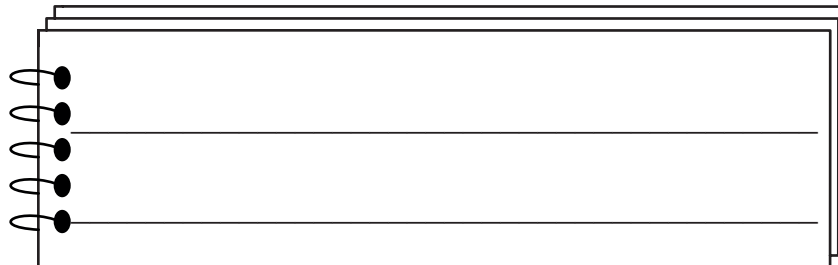
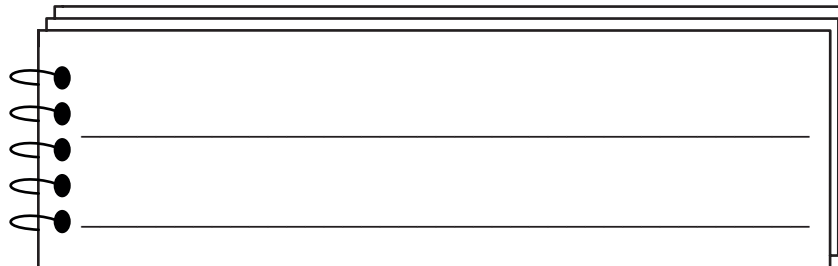
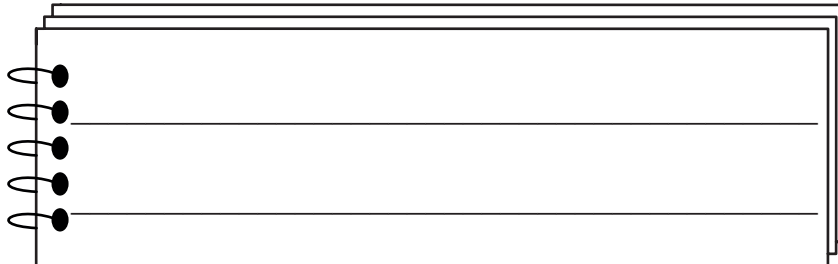

Conociendo el teatro

 Con una línea une las imágenes con las palabras que correspondan.

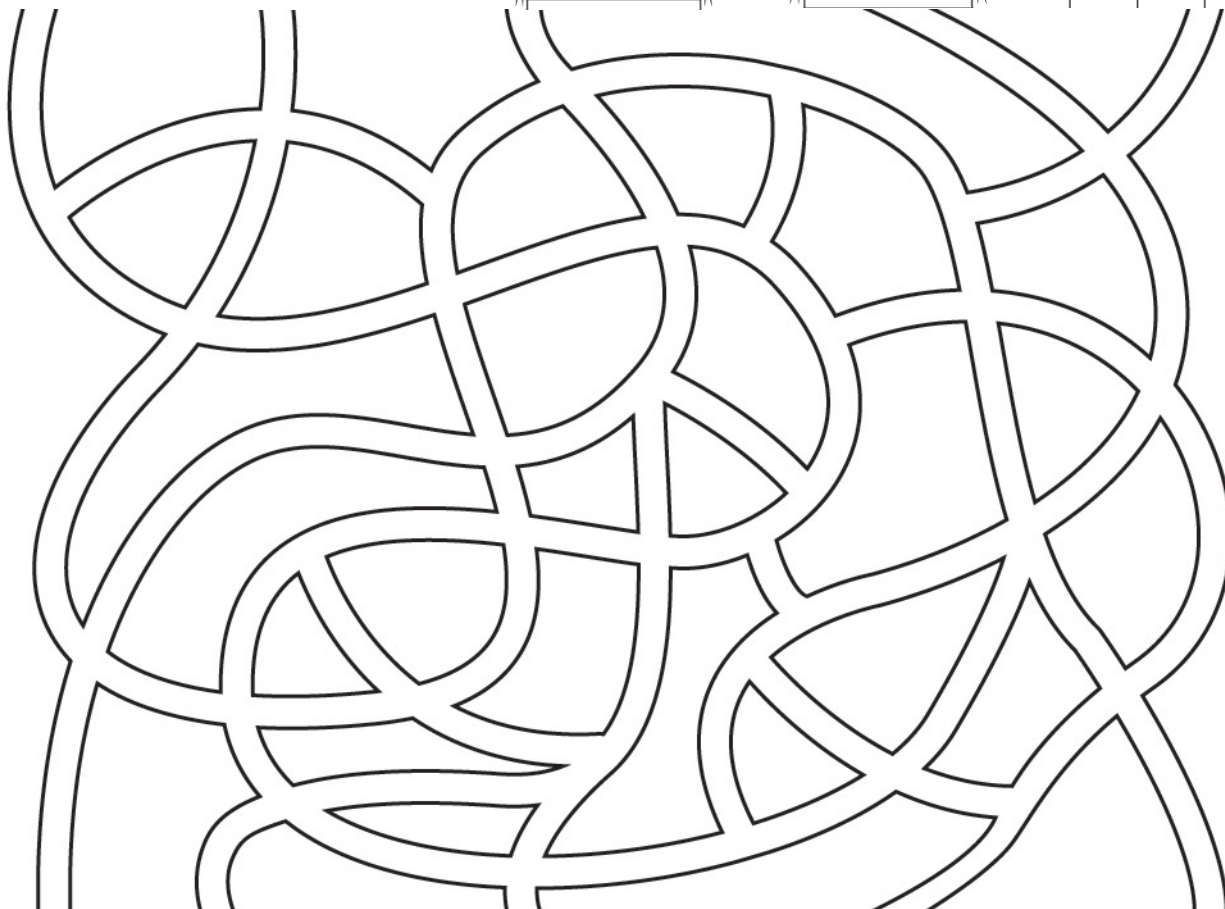
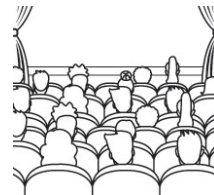
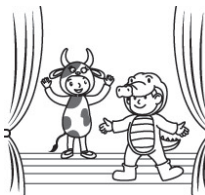
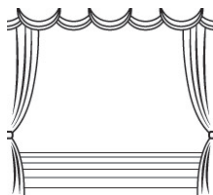

público

actores

escenario

vestuario

guion

Lo escribo con g o gu

A  Escribe el nombre de cada imagen dentro del recuadro que le corresponde.

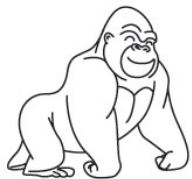

g



g



g



g

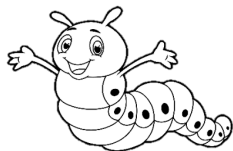

g

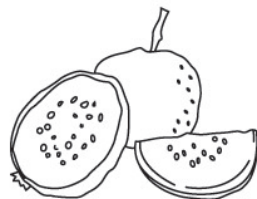

g



g

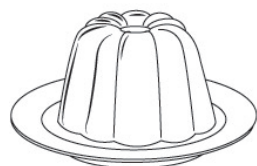

g



g



g

Tejiendo palabras

A  Escribe el nombre de cada imagen utilizando un cuadrado por letra, fíjate en el ejemplo.

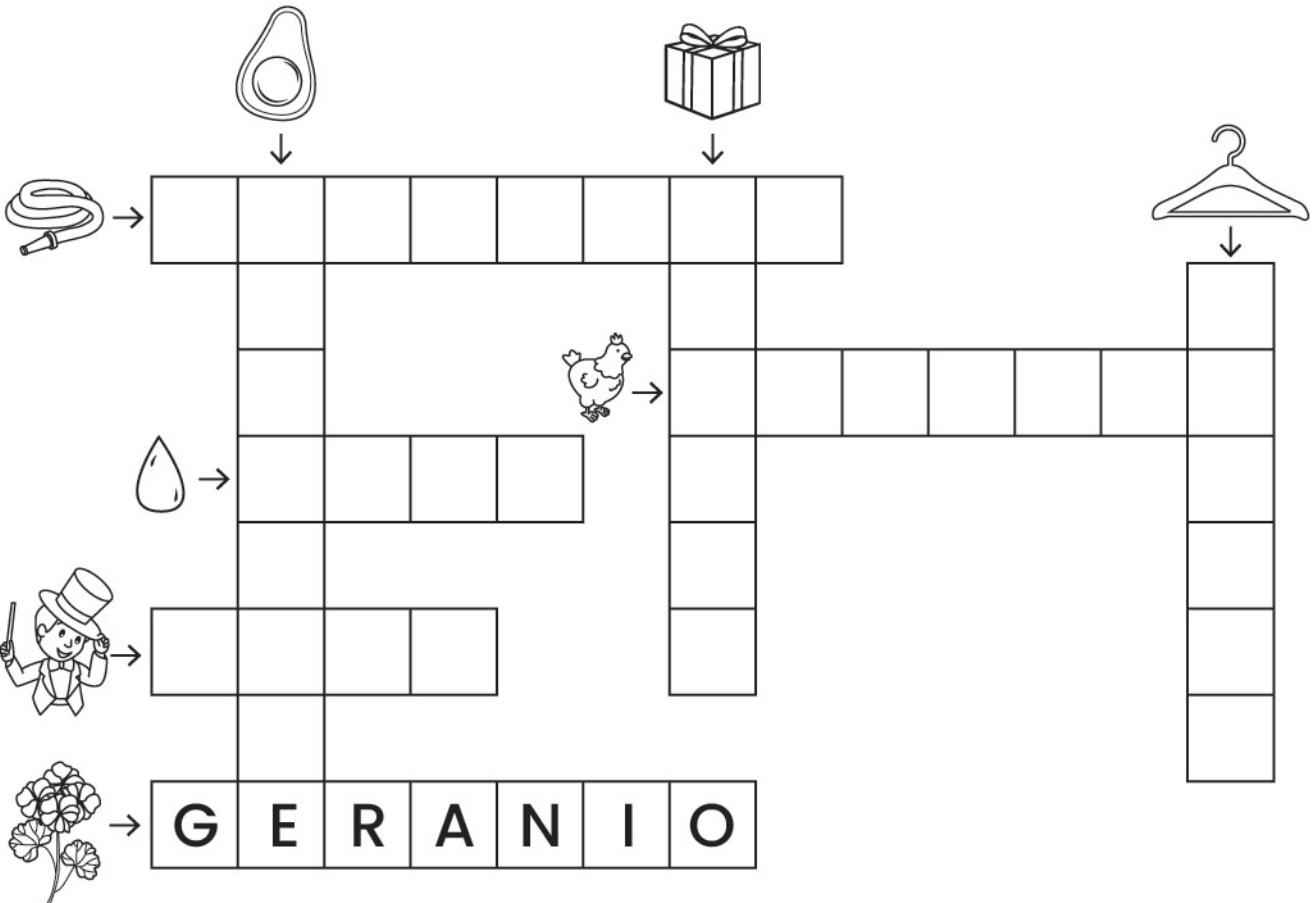

A crossword puzzle grid with the following images and their corresponding word slots:

- Avocado:** A whole avocado above a 7-letter horizontal slot.
- Gift:** A gift box above a 4-letter vertical slot.
- Snake:** A coiled snake to the left of a 7-letter horizontal slot.
- Chicken:** A chicken to the right of a 6-letter horizontal slot.
- Water drop:** A water drop to the left of a 4-letter horizontal slot.
- Magician:** A magician to the left of a 4-letter horizontal slot.
- Hanger:** A clothes hanger above a 6-letter vertical slot.
- Geranium:** A geranium flower to the left of a 7-letter horizontal slot containing the word **GERANIO**.

A  Escribe una oración utilizando el nombre de las siguientes imágenes.



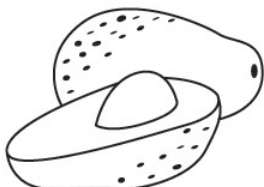

Trabalenguas

 Juega con un compañero a decir en voz alta los siguientes trabalenguas, gana el que pueda decirlos más rápido sin equivocarse.

Un ladrón
muy ladronzuelo
unos ladrillos
quiso ladropear,
de lado ladroneó el ladrón
los ladrillos del ladral
adreado ladroneó el ladrón
al oír al labrador ladrar
al ladrido, el ladronzuelo
los ladrillos se dejó
en el ladrar.

Teresa trajo unas tizas
tres tizas trajo Teresa
¿Cómo las tizas trajo?
hechas trizas
las tres tizas
Teresa trajo
¿Cómo destrozó las tizas?
tres tizas
hechas trizas
trajo Teresa
debajo del brazo.

Ganador _____

Ganador _____



R
E
C
O
R
T
A
B
L
E
S



 Recortable 1.

El Sol creó a la humanidad a partir del **sunú**(maíz) formó una figura de hombre y le sopló tres veces para darle vida. Más tarde moldeó a la **muki**(mujer).

2

Los tarahumaras son una comunidad indígena que viven en la parte de la Sierra Madre Occidental que atraviesa territorio del estado de Chihuahua, ralámuli significa "**el de los pies ligeros**" o "**corredores a pie**".

4

 Recortable 1.

Cuentan que hace muchos años, el **Rayénari**(Sol) y la **Mechá**(Luna) eran dos niños que vivían en una choza, sin luz ni compañía.

1

Al enterarse de esto, el señor de la Oscuridad, molesto y envidioso, modeló una figura de ceniza a la que le dió un soplo para vivir y así nació el hombre blanco.

3

 Recortable 1.

El origen de los Tarahumaras

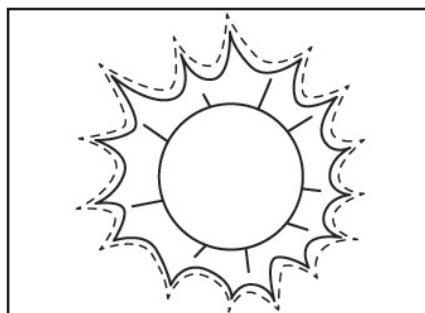
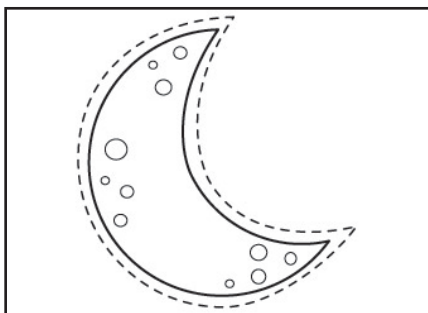
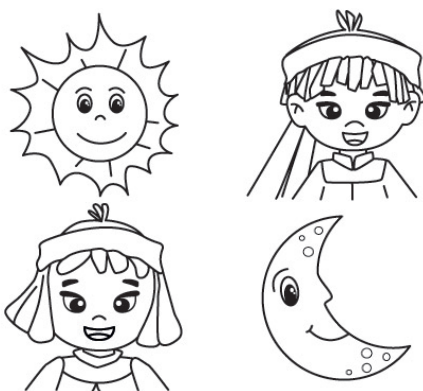

 Recortable 2.

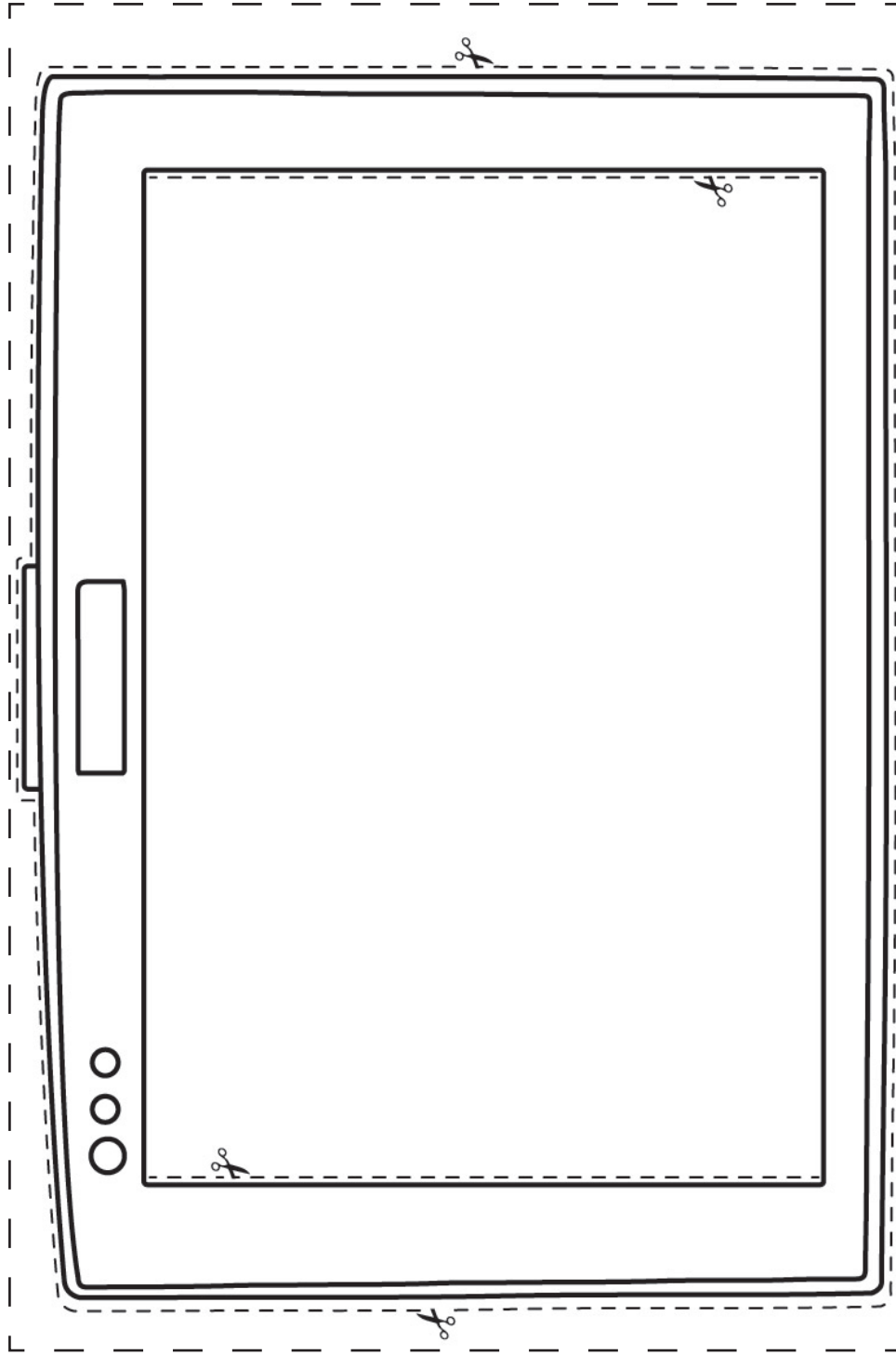

 Recortable 2.

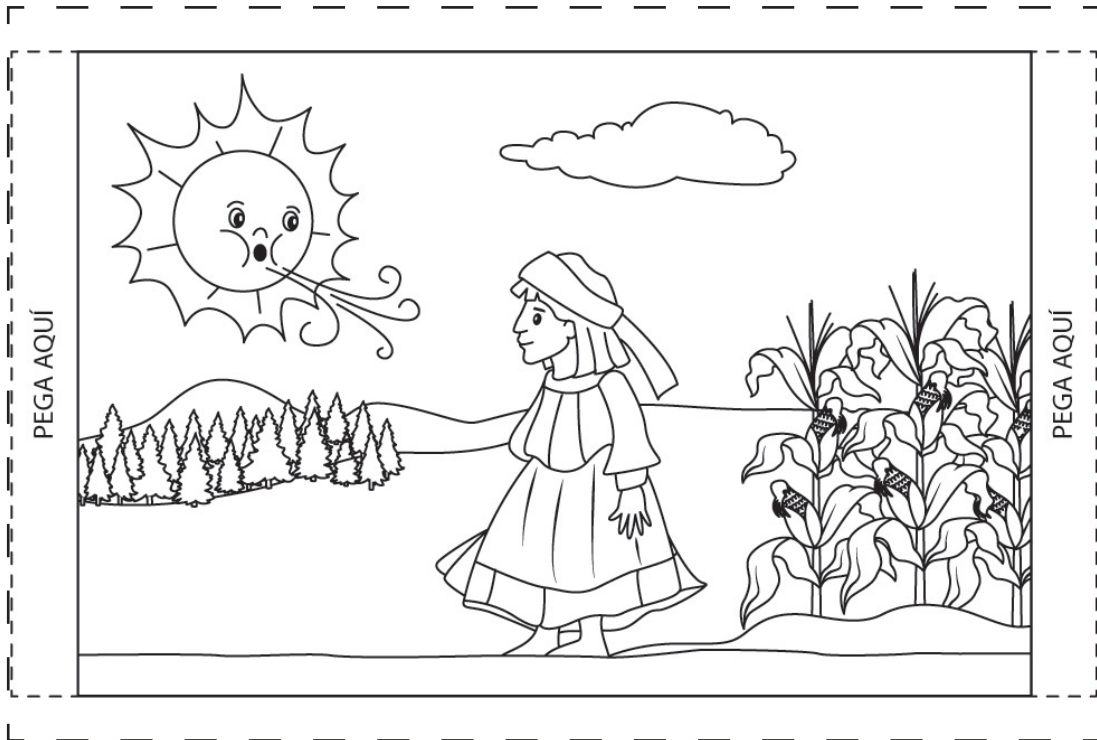
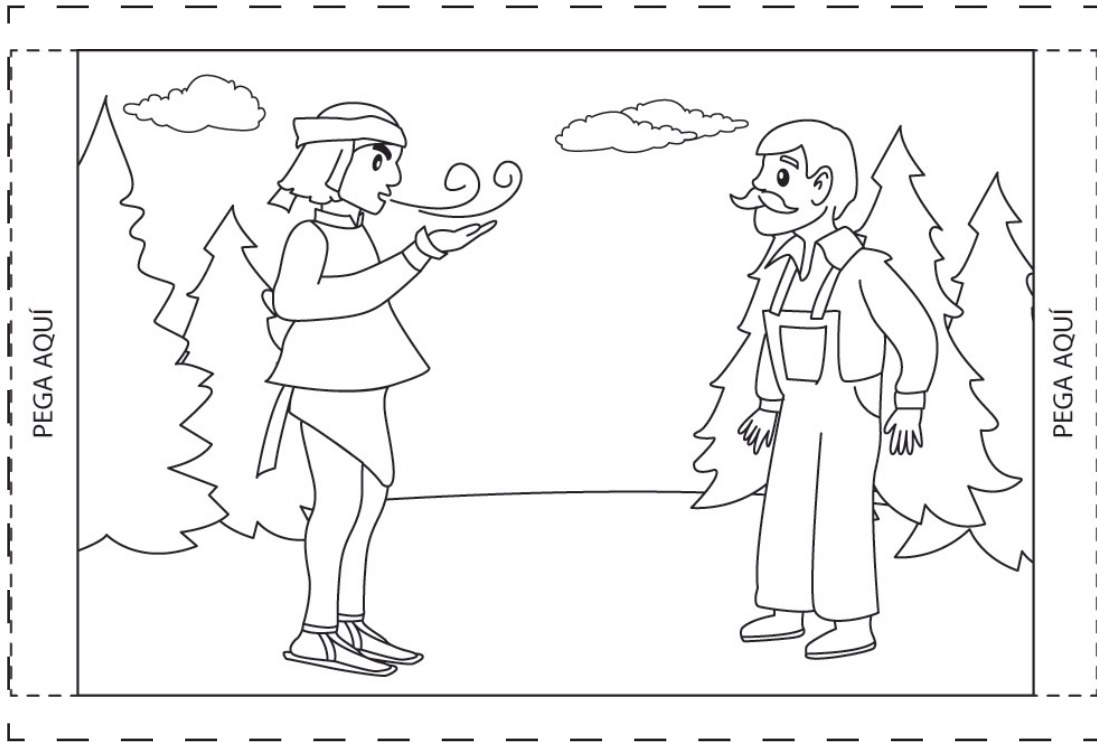

 Recortable 2.

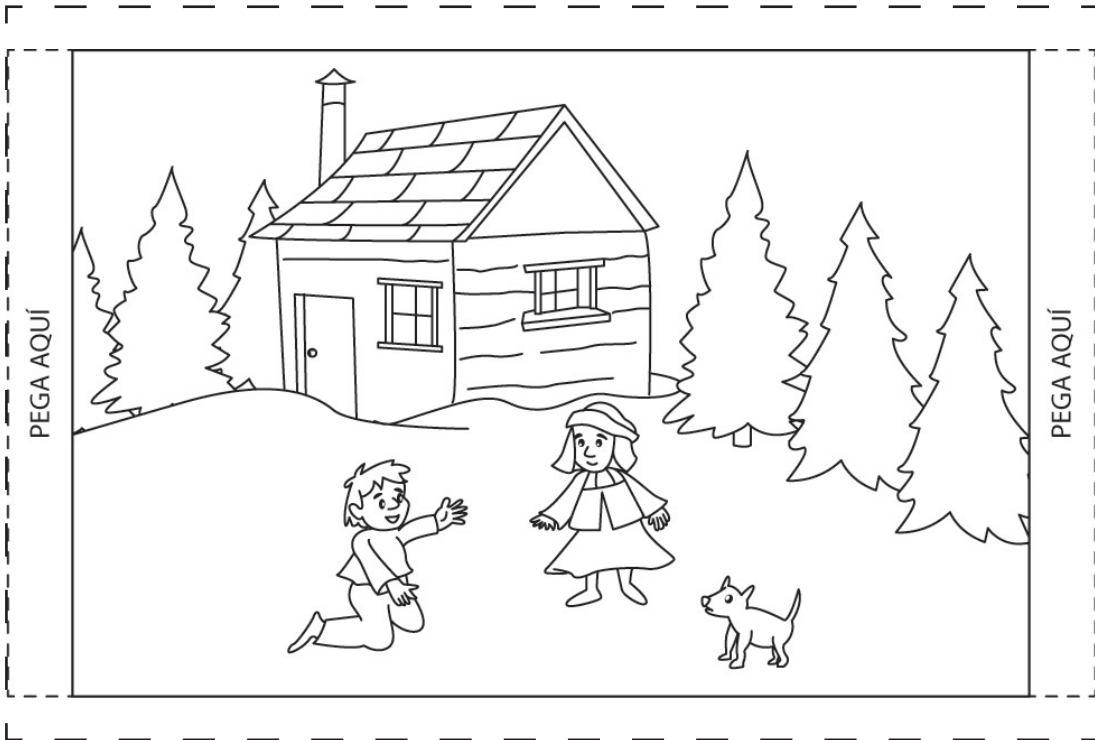
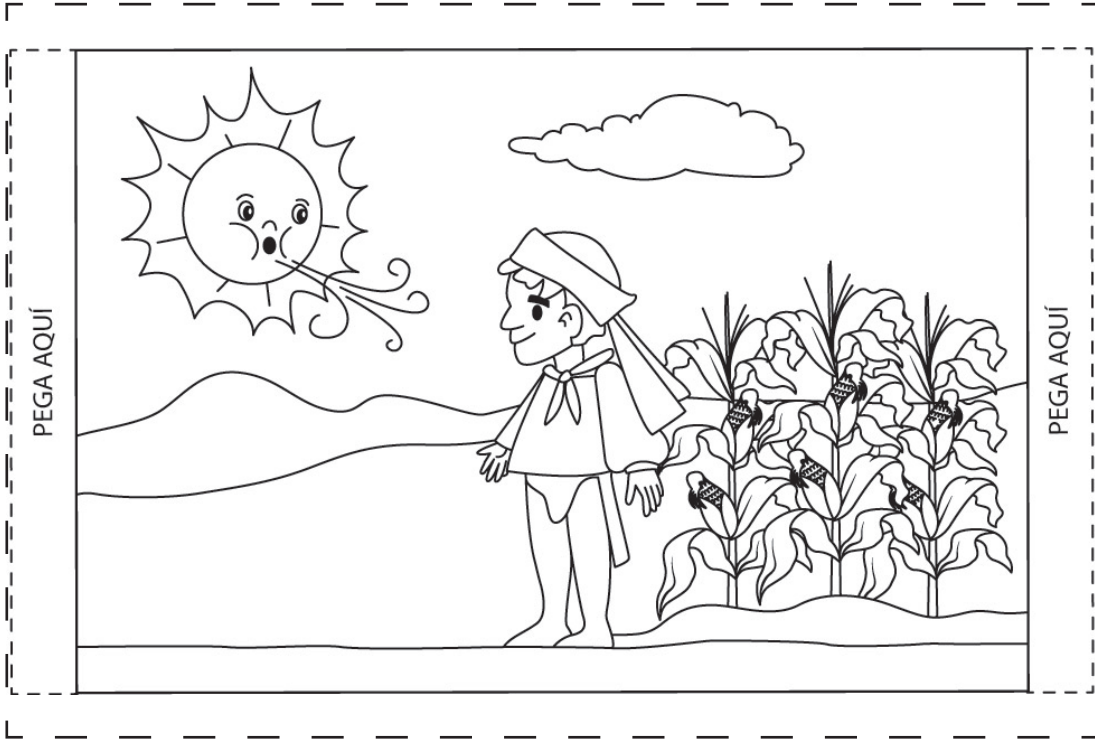

 Recortable 3.

Ana estara humar ay vive en una cueva.

Juan hace un ricopinole.

La señora María teje canastas.

 Recortable 4.

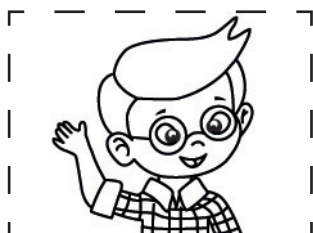
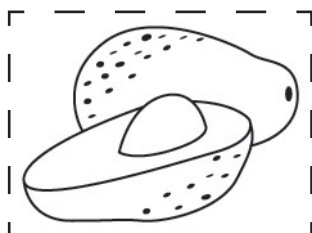
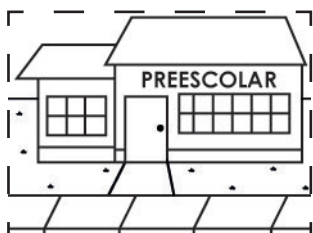
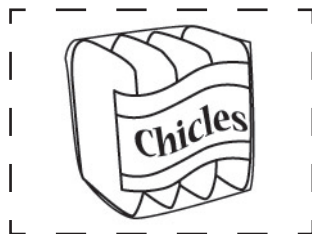

 Recortable 5.

 Recortable 5.

 Recortable 6.

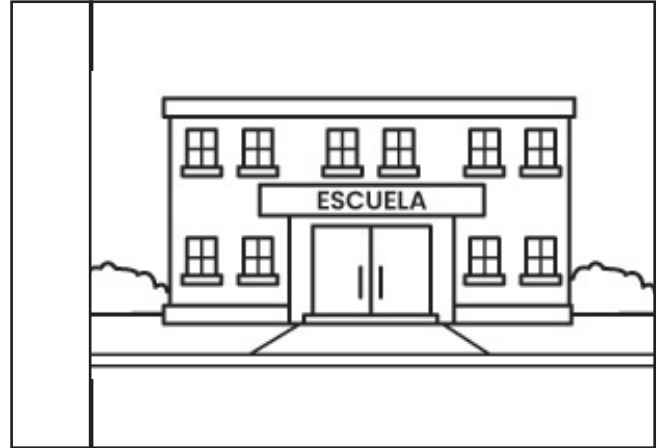

 Recortable 7.

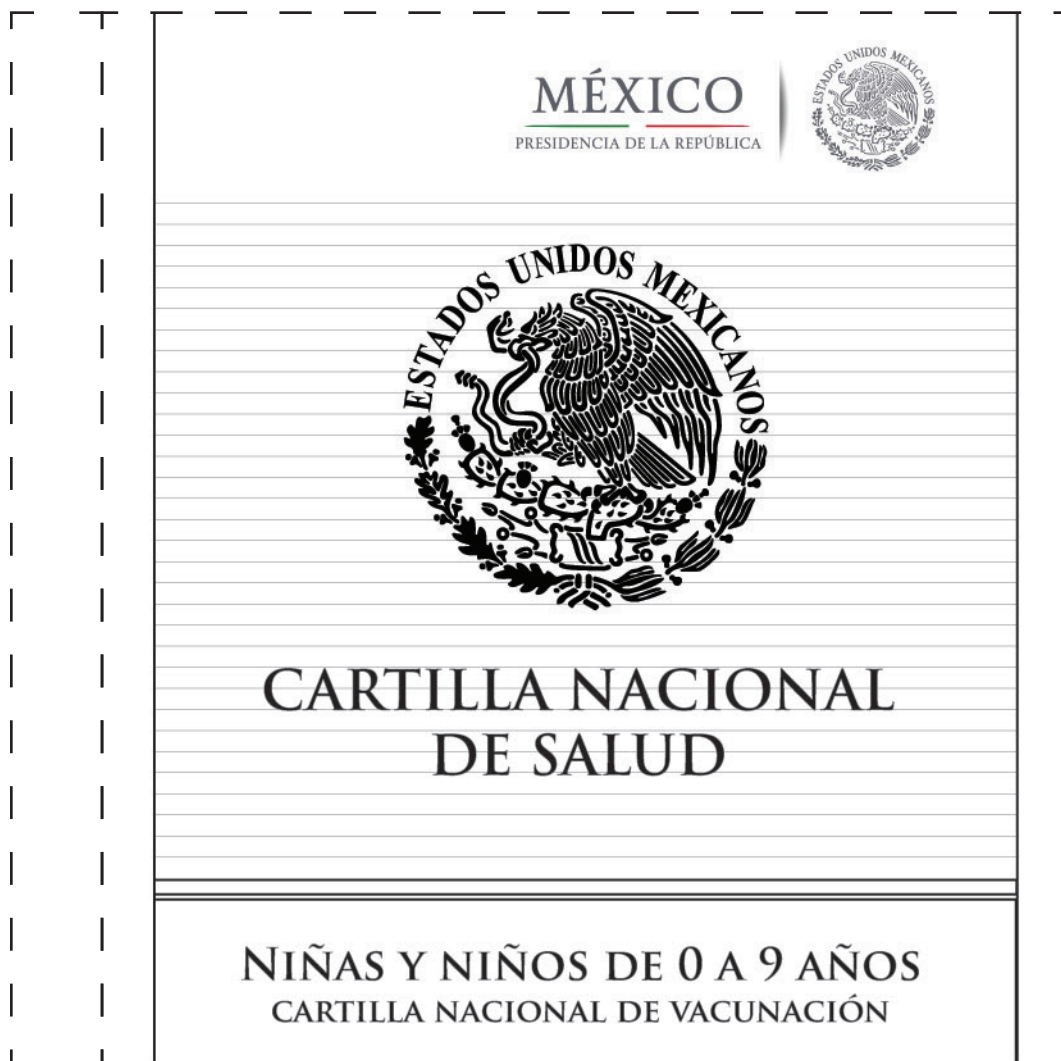

 Recortable 7.

Clave Única de Registro de población (CURP):

¿SE RECONOCE INDÍGENA?: SI NO

IDENTIFICACIÓN TIPO DE SANGRE: _____

FOTOGRAFÍA

NOMBRE Y APELLIDOS: _____

No. AFILIACIÓN/MATRÍCULA/EXPEDIENTE: _____

UNIDAD MÉDICA: _____

CONSULTORIO No. _____

DATOS GENERALES SEXO MUJER HOMBRE OTRO

DOMICILIO: _____
 CALLE Y NÚMERO

_____ COLONIA/LOCALIDAD MUNICIPIO O ALCALDÍA

_____ CÓDIGO POSTAL ENTIDAD FEDERATIVA

LUGAR Y FECHA DE NACIMIENTO: _____
 LOCALIDAD DÍA MES AÑO

_____ MUNICIPIO/ALCALDÍA/ENTIDAD FEDERATIVA/PAÍS

PERSONA RESPONSABLE:

 NOMBRE

_____ PARENTESCO _____ TELÉFONO

 Recortable 7.

ESQUEMA DE VACUNACIÓN

VACUNA	ENFERMEDAD QUE PREVIENE	DOSIS	EDAD Y FRECUENCIA	FECHA DE VACUNACIÓN
BCG	TUBERCULOSIS	ÚNICA	AL NACER	
HEPATITIS B	HEPATITIS B	PRIMERA	AL NACER	
		SEGUNDA	3 MESES	
		TERCERA	6 MESES	
PENTAVALENTE ACELULAR DPAT+VPI+HIB	DIFTERIA TOSFERINA TÉTANOS POLIOMELITIS E INFECCIONES POR H. INFLUENZA E, B	PRIMERA	2 MESES	
		SEGUNDA	4 MESES	
		TERCERA	6 MESES	
		CUARTA	18 MESES	
DPT	DIFTERIA TOSFERINA Y TÉTANOS	REFUERZO	4 AÑOS	
ROTAVIRUS	DIARREA POR ROTAVIRUS	PRIMERA	AL NACER	
		SEGUNDA	3 MESES	
		TERCERA	6 MESES	

ESQUEMA DE VACUNACIÓN

VACUNA	ENFERMEDAD QUE PREVIENE	DOSIS	EDAD Y FRECUENCIA	FECHA DE VACUNACIÓN
NEUMOCÓCICA CONJUGADA	INFECCIONES POR NEUMOCOCO	PRIMERA	2 MESES	
		SEGUNDA	4 MESES	
		TERCERA	12 MESES	
INFLUENZA	INFLUENZA	PRIMERA	2 MESES	
		SEGUNDA	4 MESES	
		REVACUNACIÓN	ANUAL HASTA LOS 59 MESES	
SRP	SARAMPIÓN RUBEOLA Y PAROTIDITIS	PRIMERA	1 AÑO	
		REFUERZO	6 AÑOS	
SABIN	POLIOMELITIS	ADICIONALES		
SR	SARAMPEÓN Y RUBEOLA	ADICIONALES		
OTRAS VACUNAS				

 Recortable 8.

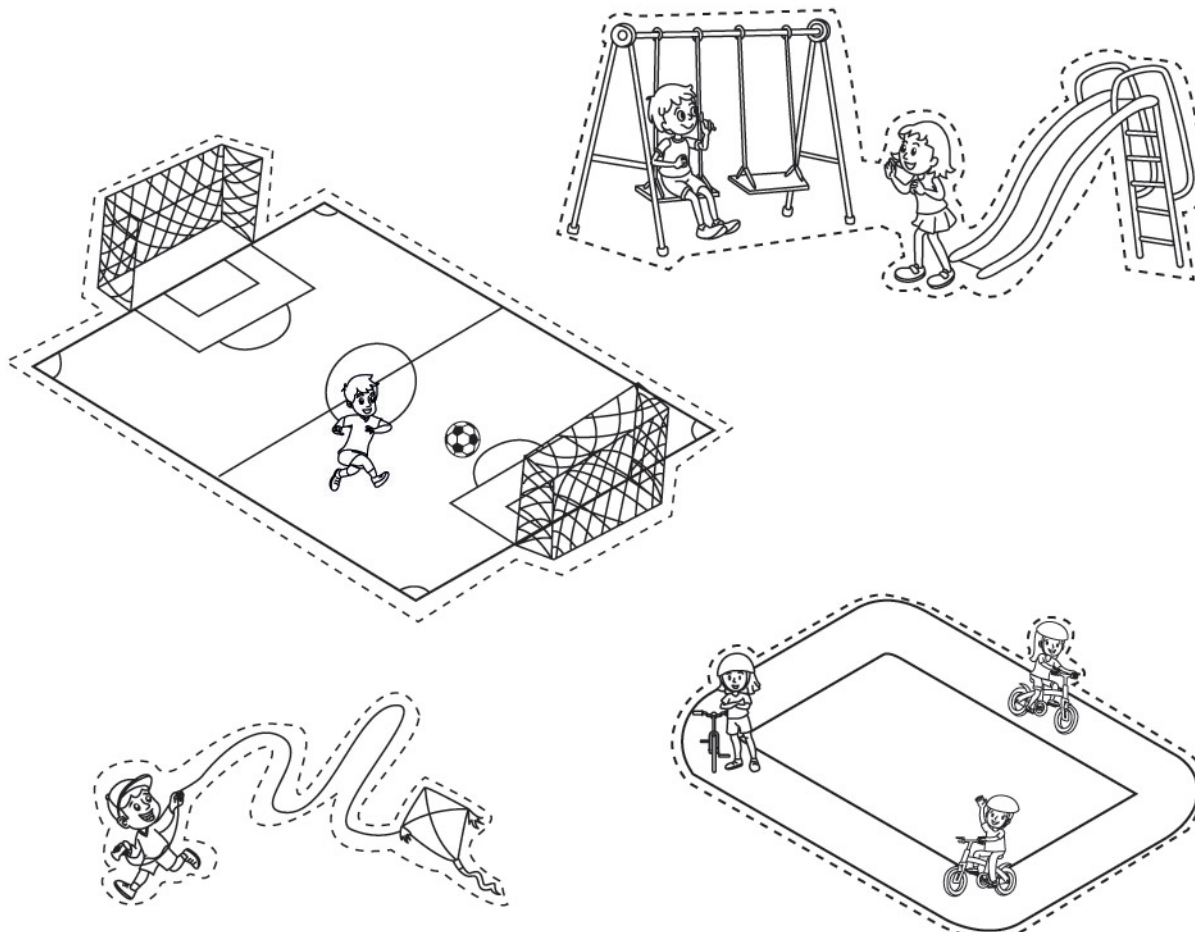

APRENDIZAJE ESPERADO: Lee, escribe y ordena números naturales hasta 1000.

A contar

A  Completa la tabla y acomoda los números en la columna de centenas, decenas y unidades según corresponda.

NÚMEROS	CENTENAS	DECENAS	UNIDADES
$500+90+3$			
865			
$600+90+10$			
$385+20+8$			

 Con ayuda del recortable 1 juega a la refresquería.

 El juego consiste en:

Instrucciones:

Nivel 1.

1. Pueden jugar a partir de 2 participantes.
2. Decidan quién inicia el juego.
3. Ponen al centro los refrescos sueltos, las tiras de 10 refrescos y las cajas con 100.
4. El primer jugador lanza el dado y toma del centro el total de refrescos que le salió en el dado.
5. Al terminarse los refrescos sueltos, deberá intercambiar por tiras con 10 o por cajas con 100.
6. Gana el jugador que junte más refrescos.

Nivel 2.

1. Pueden jugar a partir de 2 participantes.
2. Decidan quién inicia el juego.
3. Ponen al centro los refrescos sueltos, las tiras de 10 refrescos y las cajas con 100.
4. El primer jugador lanza el dado de las decenas y el de las unidades, toma del centro la cantidad de refrescos que corresponda a lo que le salió en ambos dados.
5. Al terminarse los refrescos sueltos, deberá intercambiar por tiras con 10 o por cajas con 100.
6. Gana el jugador que junte más refrescos.

A Representen en el odómetro del recortable 2 los resultados obtenidos para conocer al ganador.

C	D	U

C	D	U

Formando cantidades

A Con ayuda del odómetro, representa los siguientes números y escríbelos en el cuadro de la derecha.

3 cajas con 100 refrescos cada una y 11 refrescos sueltos.

58 tiras con 10 refrescos cada una y 4 refrescos sueltos.

5 cajas con 100 refrescos cada una y 38 refrescos sueltos.

3 cajas con 100 refrescos cada una y 2 tiras de 10 refrescos.

42 tiras de 10 refrescos cada una y 0 refrescos sueltos.

5 cajas de 100 refrescos cada una, 8 tiras de 10 refrescos y 4 refrescos sueltos.

30 tiras de 10 refrescos cada una y 20 refrescos sueltos.

¿Cuáles cantidades son iguales? _____

De las cantidades formadas, ¿cuál es la mayor? _____

¿Cuál cantidad tiene 100 más que la de 320? _____

Guerra de cartas

 Utiliza el recortable 3 y juega a guerra de cartas.

Instrucciones:

Nivel 1

1. Recorta las tarjetas.
2. invita a un compañero a jugar.
3. Revuelvan las tarjetas y colóquenlas al centro con los números hacia abajo.
4. Tomen del centro 3 cartas cada uno y formen la cantidad mayor con los números de las tarjetas.
5. Quien pueda representar el número mayor, se queda con las tarjetas.
6. Gana quién junte más tarjetas.

Nivel 2

1. Recorta las tarjetas.
2. invita a un compañero a jugar.
3. Revuelvan las tarjetas y colóquenlas al centro con los números hacia abajo.
4. Tomen del centro 3 cartas cada uno y formen la cantidad menor con los números de las tarjetas.
5. Quien pueda representar el número menor, se queda con las tarjetas.
6. Gana quién junte más tarjetas.



Número mayor

 Colorea a los niños del equipo que forma el número.

Mayor.

Equipo 1

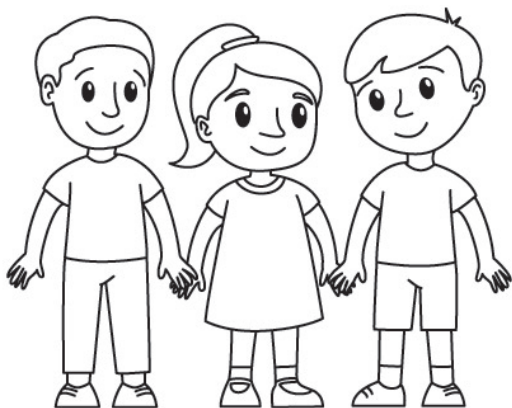

Equipo 2



Menor.

Equipo 3



Equipo 4

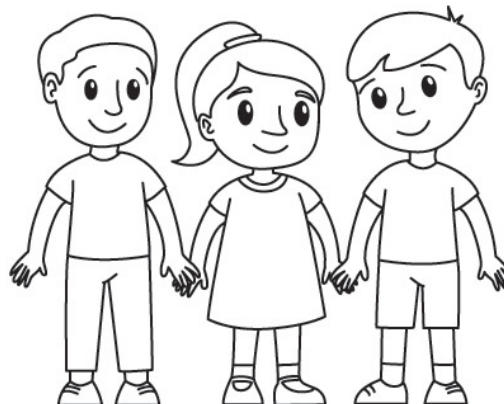

APRENDIZAJE ESPERADO: Calcula mentalmente sumas y restas de números de dos cifras, dobles de números de dos cifras y mitades de números pares menores que 100.

De 10 en 10

 Utiliza el recortable 4 y pega los números en los recuadros sumando de 10 en 10 a partir del 525.

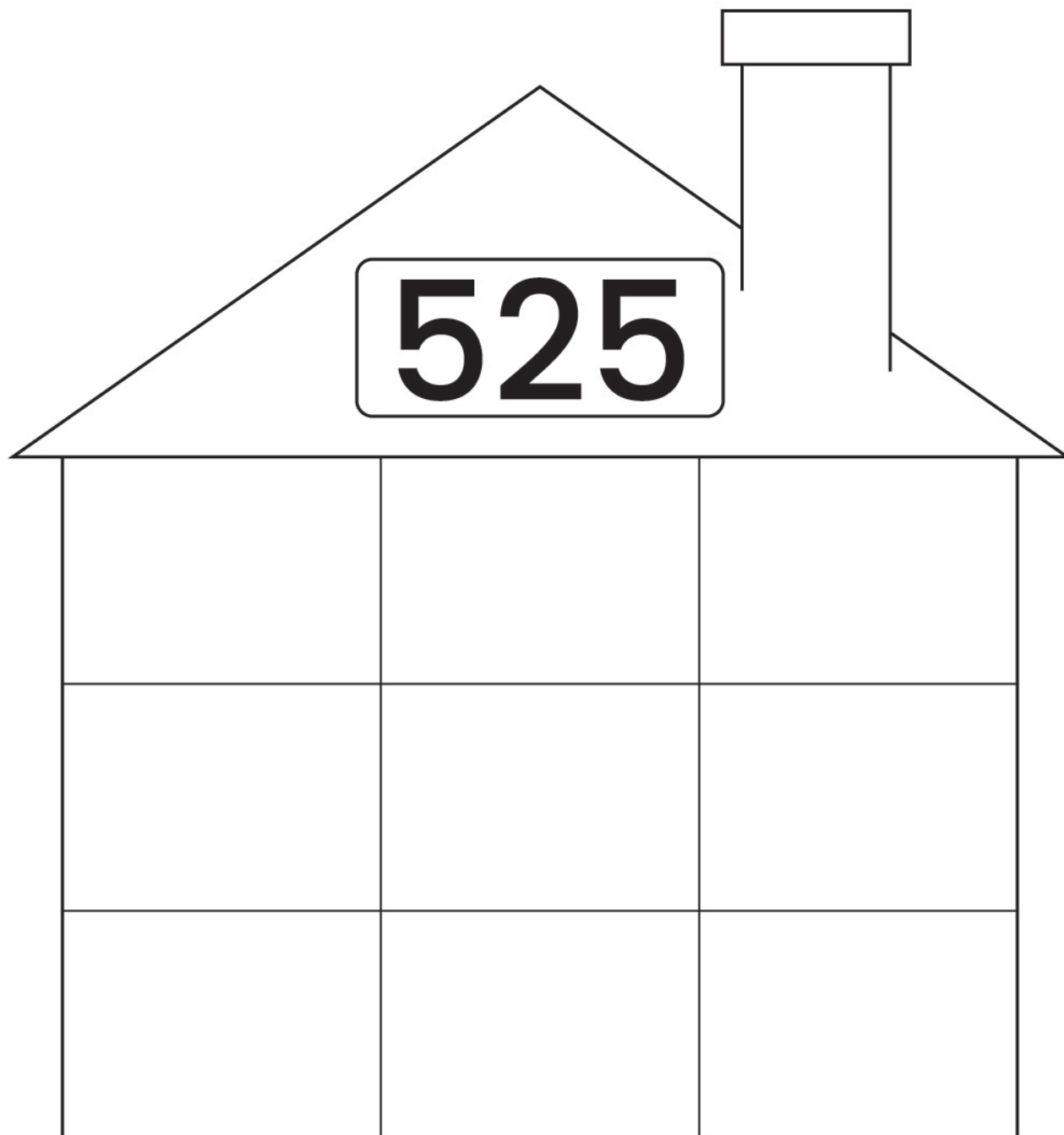

Ordenando

 Descubre la serie pintando los animales de la siguiente imagen.

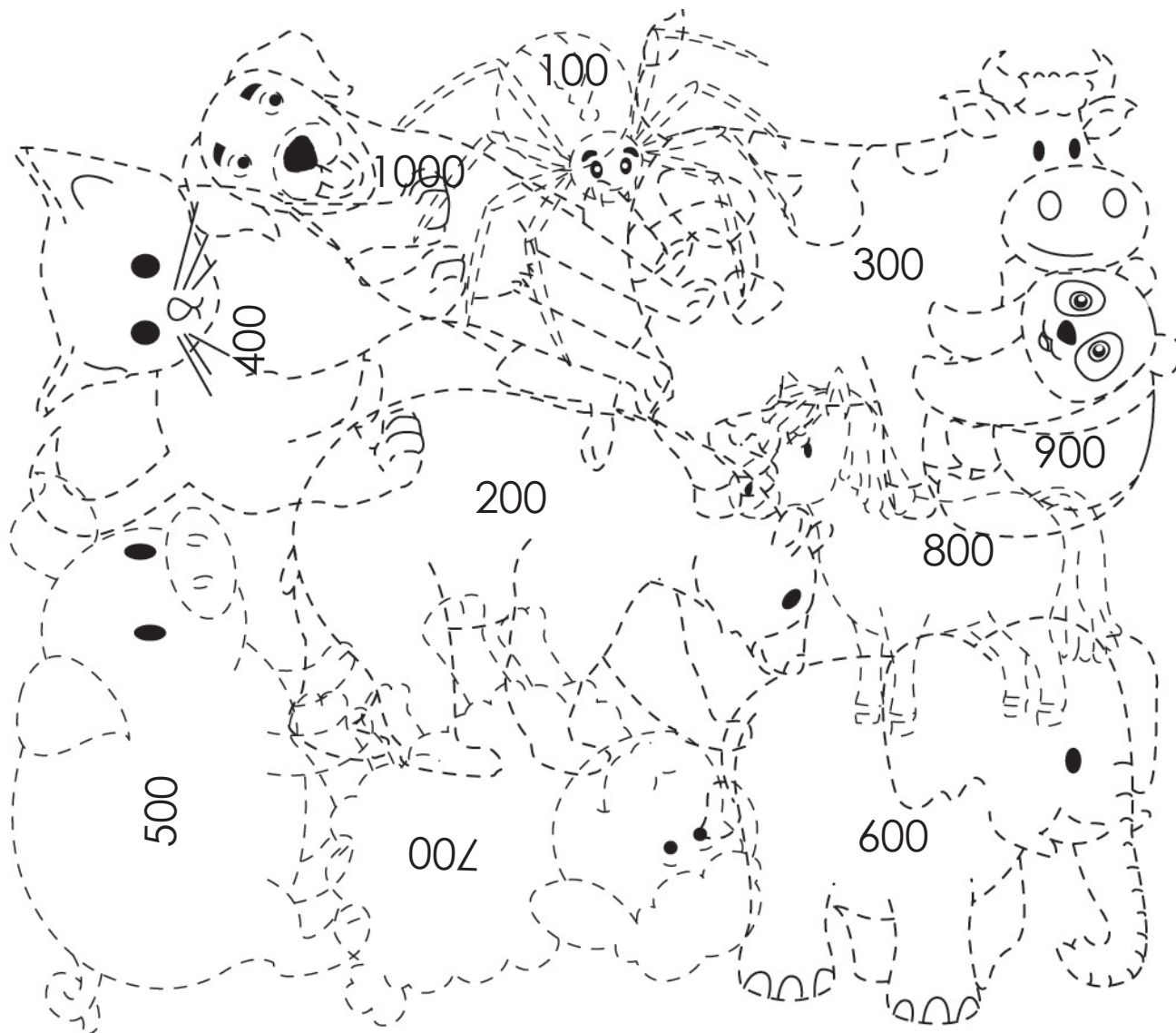

 Utiliza los números que tiene cada animal y escríbelos en orden.

100				
-----	--	--	--	--

--	--	--	--	--

Cien menos

 Colorea de amarillo los resultados de las siguientes restas y escríbelo.

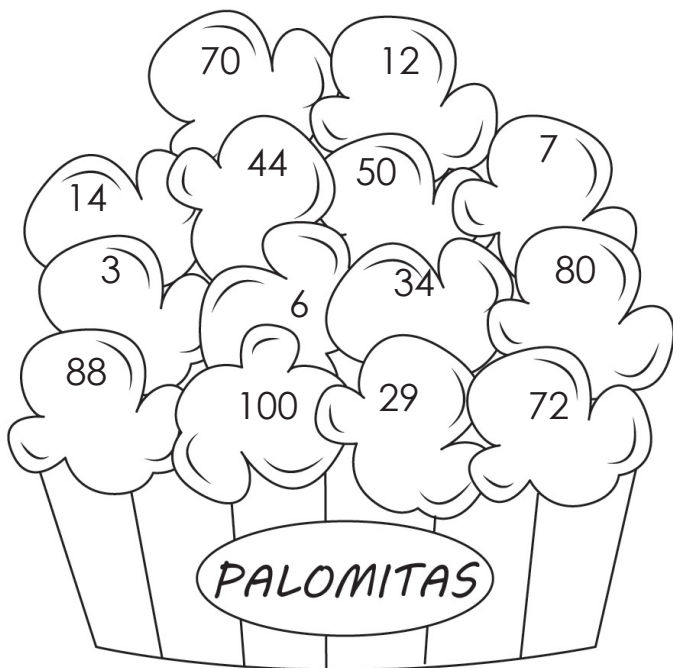

$100 - 28 = \underline{\hspace{2cm}}$

$100 - 56 = \underline{\hspace{2cm}}$

$100 - 12 = \underline{\hspace{2cm}}$

$100 - 93 = \underline{\hspace{2cm}}$

$100 - 66 = \underline{\hspace{2cm}}$

 Calcula cuánto le falta a las siguientes cantidades para completar 100.

¿Cuánto le falta a 15 para 100?

¿Cuánto le falta a 44 para 100?

¿Cuánto le falta a 81 para 100?

APRENDIZAJE ESPERADO: Estima, mide, compara y ordena longitudes y distancias, pesos y capacidades, con unidades no convencionales y el metro no graduado, el kilogramo y el litro, respectivamente.

Midiendo

 Colorea los cuadros para saber cuánto mide cada objeto.

 Escribe el resultado en cada línea.







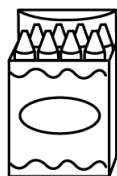





¿Cómo medimos?

A Utiliza el recortable 5 y arma el metro para que puedas medir los siguientes objetos en tu casa o escuela.

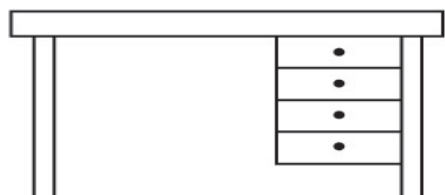

mide _____



mide _____

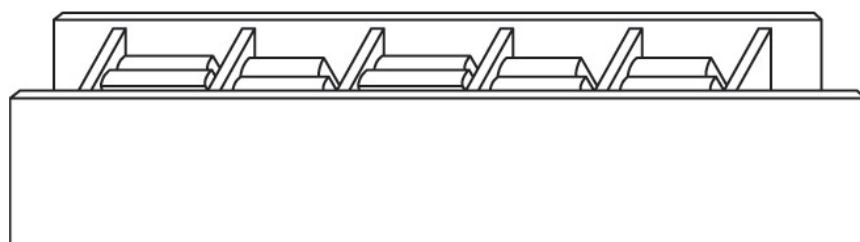

mide _____



mide _____

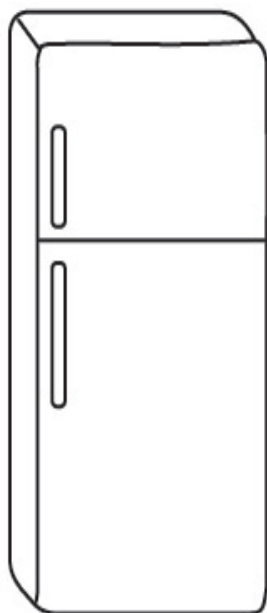

mide _____

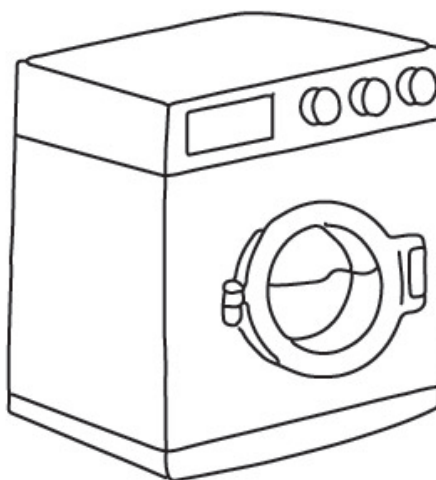

mide _____

APRENDIZAJE ESPERADO: Resuelve problemas de suma y resta con números naturales hasta 1000.

Canguros saltando

👁️👁️ Observa los saltos que da la familia canguro y contesta.

Papá canguro salta de:



Mamá canguro salta de:

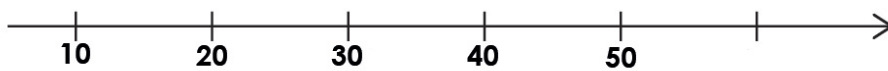

Bebé canguro salta de:



A ¿Llegaron al mismo número? _____

¿Por qué? _____

¿Cuántos saltos dió el papá canguro para llegar al 50? _____

¿Cuántos saltos dió la mamá canguro para llegar al 50? _____

¿Cuántos saltos dió el bebé canguro para llegar al 50? _____

Salta con la familia canguro

A Utiliza el recortable 6 para resolver las siguientes sumas.

$350 + 150 =$

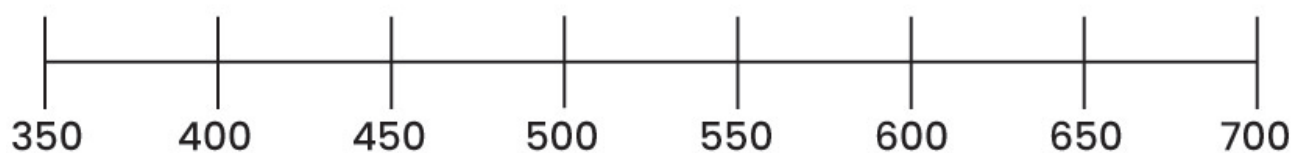

$125 + 103 =$

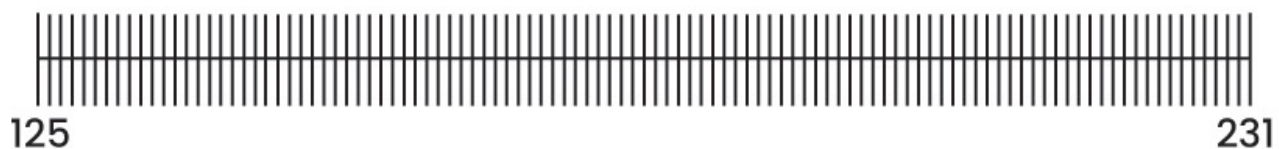

$270 + 120 =$

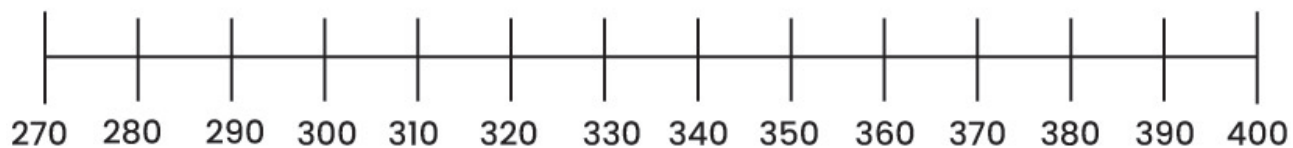

APRENDIZAJE ESPERADO: Calcula mentalmente sumas y restas de números de dos cifras y mitades de números pares menores que 100.

Intercambiando

A Utiliza el recortable 7 para realizar el siguiente ejercicio.

Luisa tiene esta cantidad de monedas.

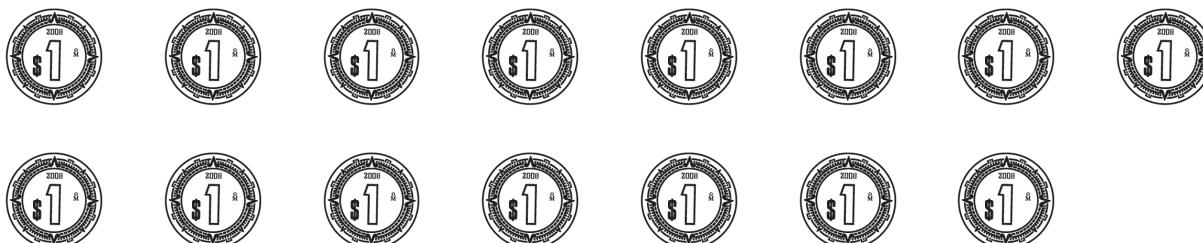

¿Por cuántas monedas de 10 pesos lo puede intercambiar y cuántas monedas de 1 peso le quedan?

Pedro tiene esta cantidad de monedas.

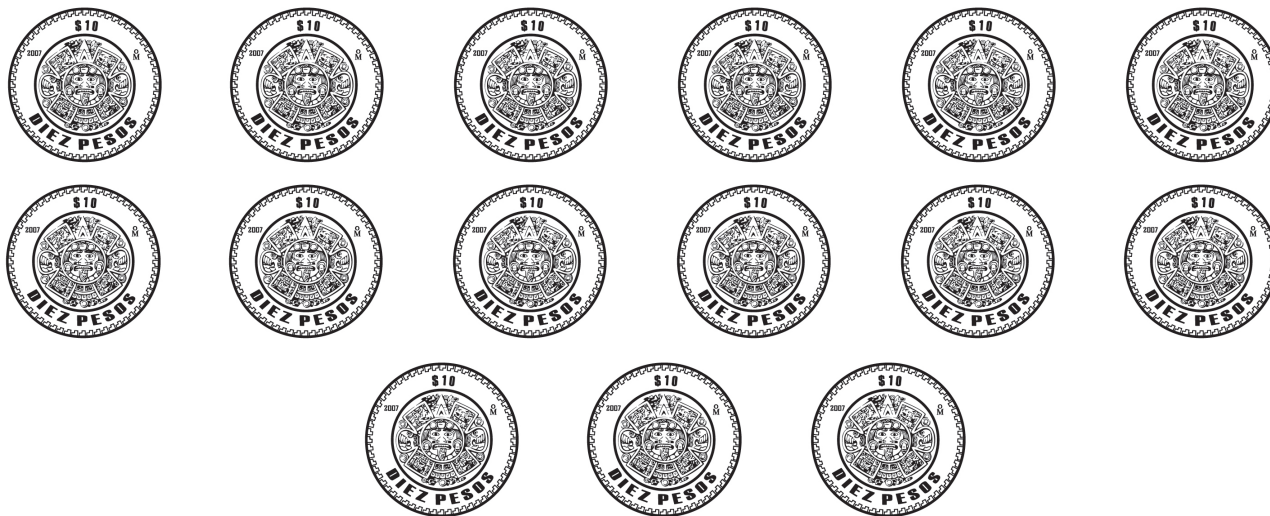

¿Por cuántos billetes de 100 pesos lo puede intercambiar y cuántas monedas de 10 pesos le quedan?

Ana tiene esta cantidad de dinero.

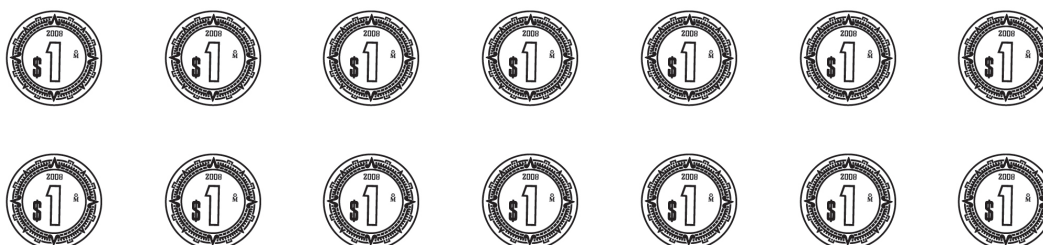

¿Por cuántos billetes de 100 pesos puede intercambiar las monedas de 10 pesos y 1 peso? y ¿cuántas monedas de 10 pesos y de 1 peso le quedan?

APRENDIZAJE ESPERADO: Completa centenas al sumar números de dos y tres cifras.

El gusano sumador

 Dibuja los círculos que necesites para resolver de manera rápida las siguientes sumas. Fíjate en el ejemplo.

$$125 + 75 = 200$$

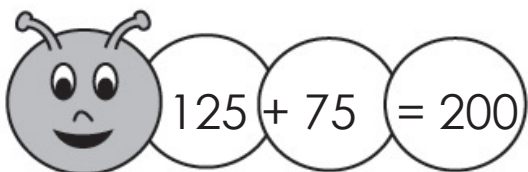

$$310 + 28 =$$



$$206 + 14 =$$



$$118 + 36 =$$



$$148 + 120 =$$





$$529 + 201 =$$





Sumar o restar

A  Completa los datos que faltan en cada una de las sumas.

 $35 + \text{ } = 250$

 $870 + 80 = \text{ }$

 $\text{ } + 315 = 410$

 $535 + \text{ } = 705$

 $125 + 75 = \text{ }$

 $\text{ } + 70 = 210$

Completa centenas

A Ayuda a cada niño a saber cuánto dinero tiene ahorrado.



Luisa

7 de cien
20 de diez
8 de uno



Cien	Diez	Uno



Pedro

5 de cien
15 de diez
12 de uno



Cien	Diez	Uno



Luis

3 de cien
10 de diez
3 de uno



Cien	Diez	Uno



Ana

1 de cien
10 de diez
10 de uno



Cien	Diez	Uno

APRENDIZAJE ESPERADO: Encuentra complementos a mil.

Completando

A  Anota la respuesta que falta para completar 1 000.

¿Cuánto le falta a 525 para 1 000?

260

¿Cuánto le falta a 740 para 1 000?

340

550

475

620

¿Cuánto le falta a 380 para 1 000?

¿Cuánto le falta a 660 para 1 000?

¿Cuánto le falta a 450 para 1 000?

Hasta el mil

 Utiliza el recortable 8 para armar los rompecabezas que al sumar dos piezas se completen 1 000.

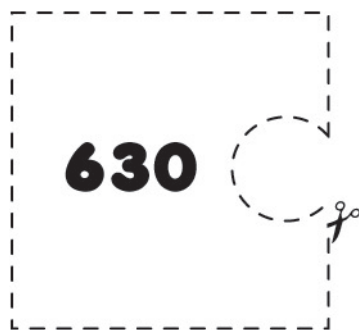
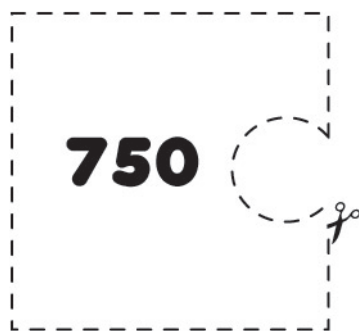
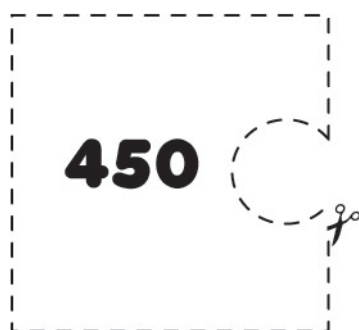
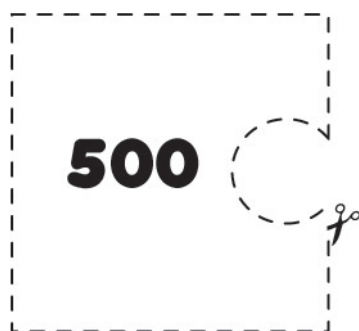

APRENDIZAJE ESPERADO: Identifica la relación que existe al multiplicar por 3.

De tres en tres

 Utiliza el recortable 9 y pega los pétalos alrededor del centro de la flor según corresponda.

De 3 en 3

De 5 en 5

De 6 en 6

De 8 en 8

Encontrando su pareja

 Une el helado con el vaso realizando las multiplicaciones. Utiliza el recortable 10.



APRENDIZAJE ESPERADO: Construye y describe figuras y cuerpos geométricos.

Creando

 Sigue las instrucciones para dibujar los siguientes mosaicos.

Divide el cuadrado en cuatro triángulos iguales y colorea de verde dos triángulos opuestos.

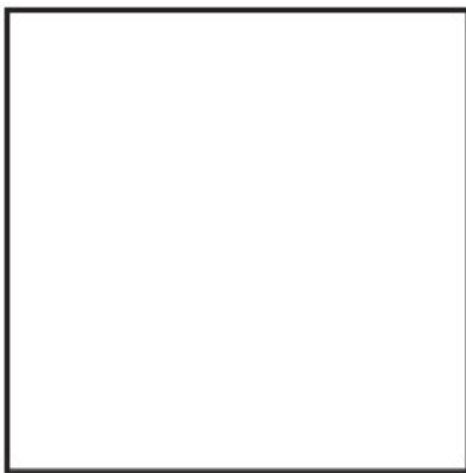

Divide el cuadrado en dos rectángulos iguales y los rectángulos divídelos en dos triángulos iguales cada uno.

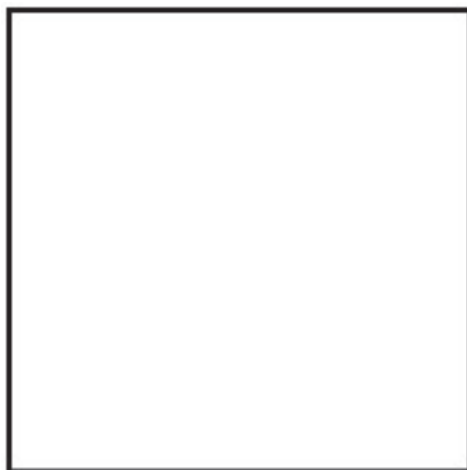

Jugando con cuadros

 Une con una línea los cuadrados con la descripción que corresponde.

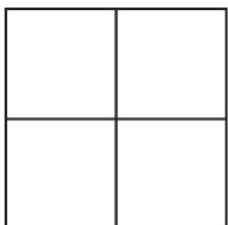

Cuadrado.

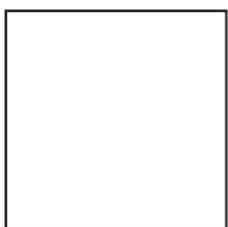

Cuadrado dividido en cuatro cuadrados iguales.

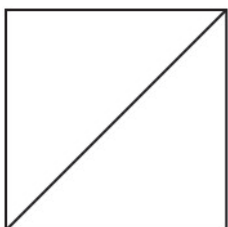

Cuadrado dividido en dos rectángulos iguales.

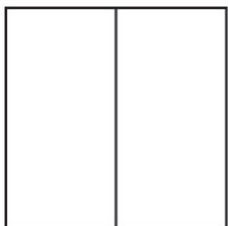

Cuadrado dividido en dos triángulos iguales.

R
E
C
O
R
T
A
B
L
E
S



 Recortable 1.

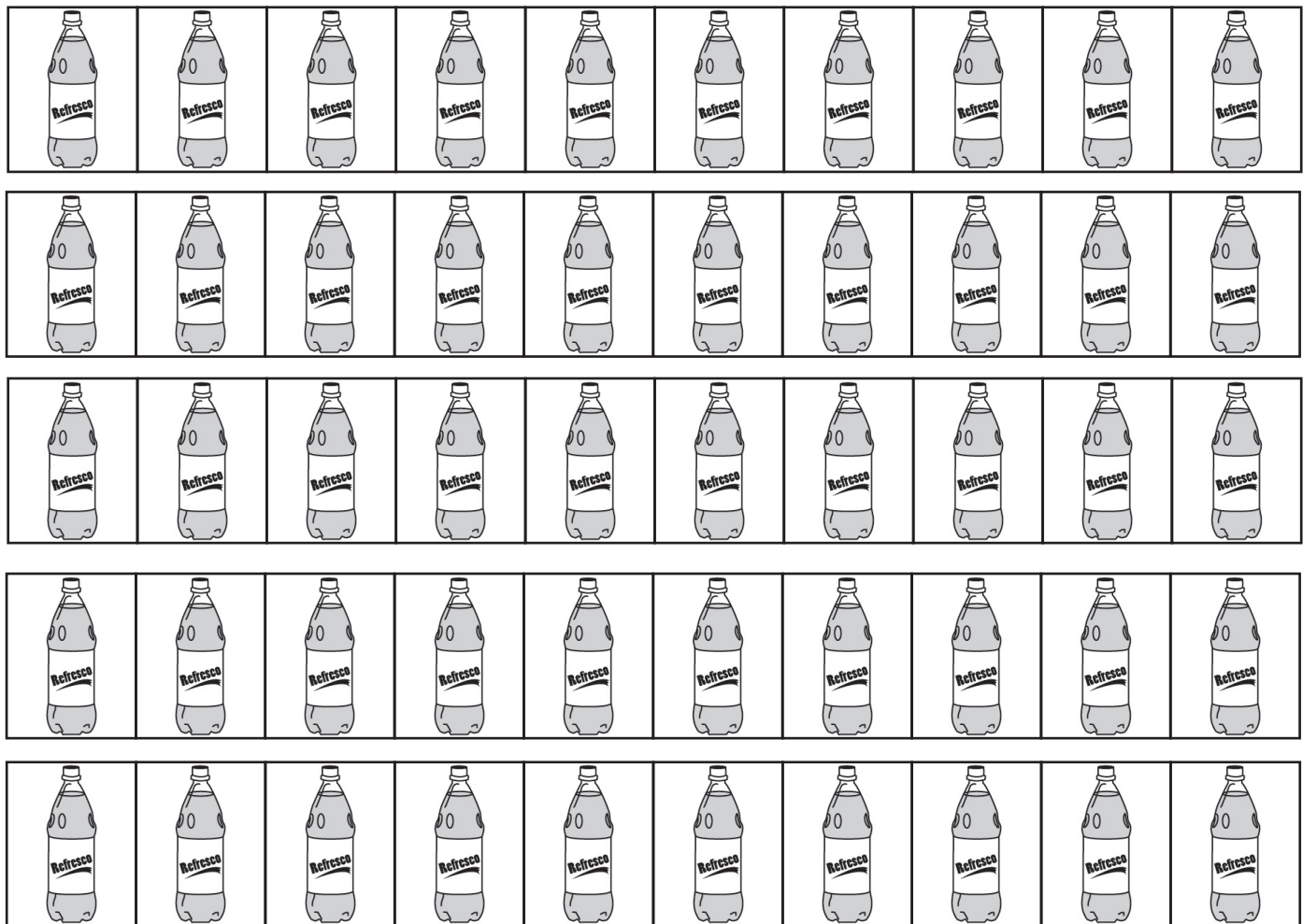
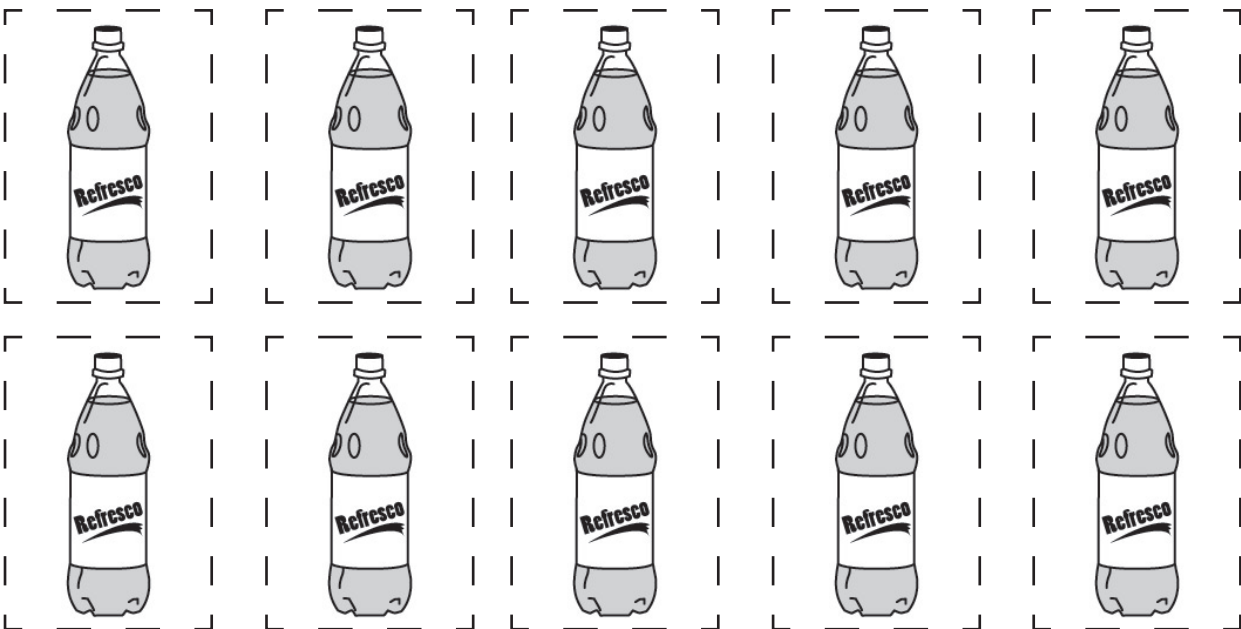

 Recortable 1.

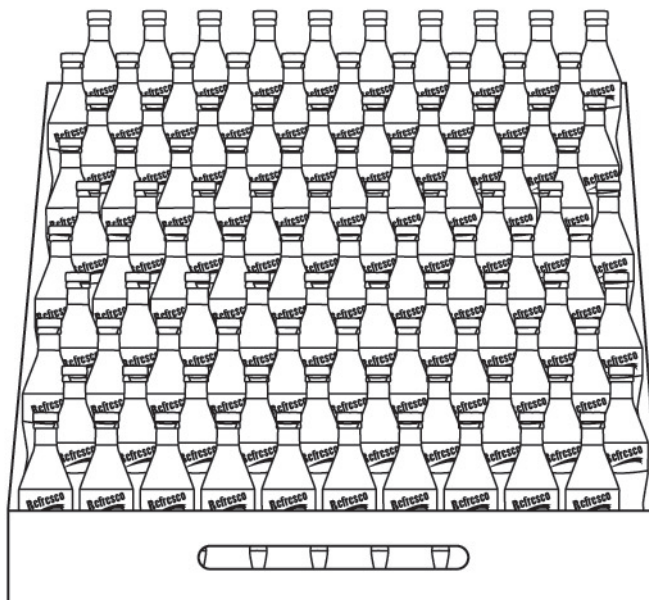
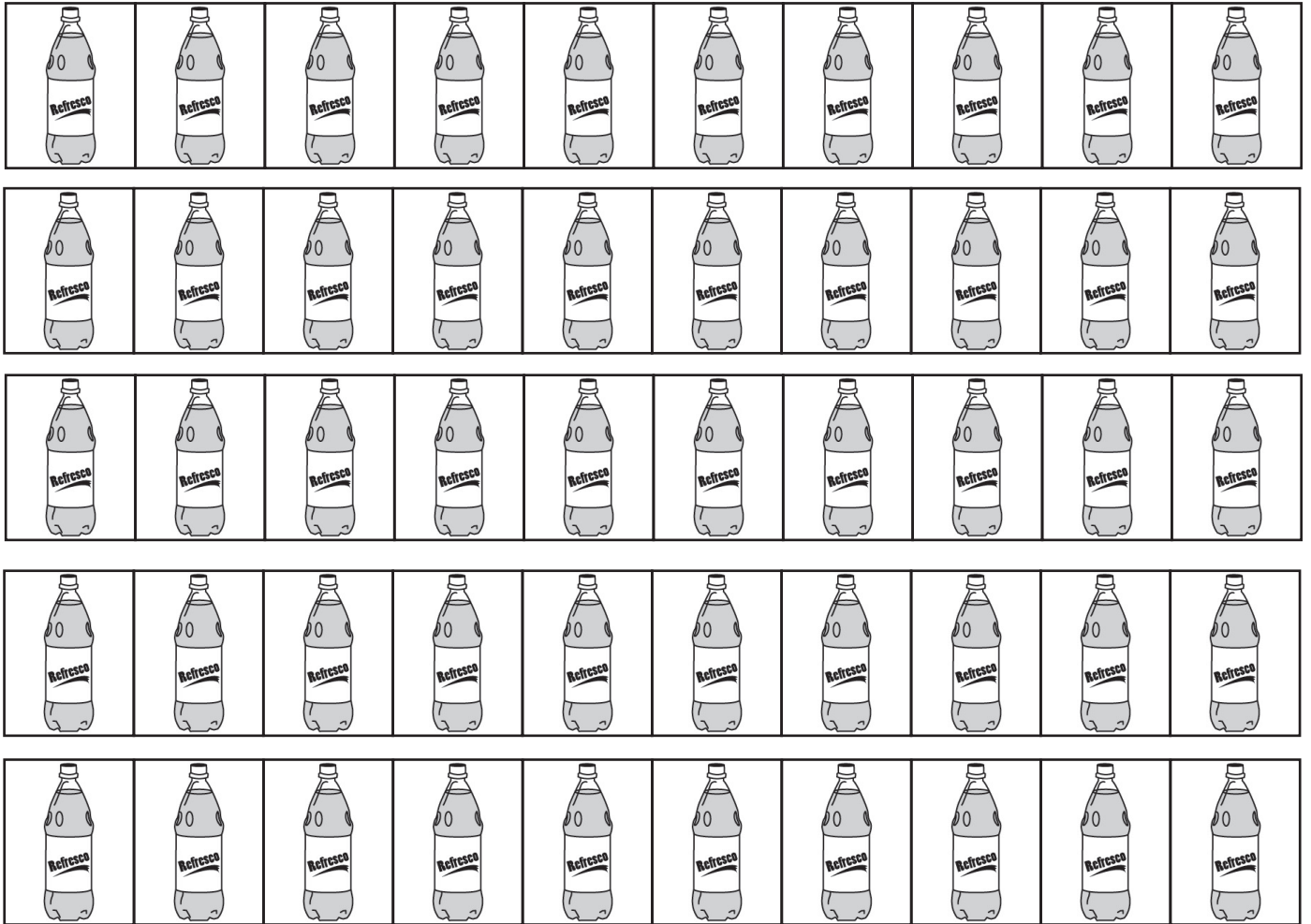

 Recortable 1.

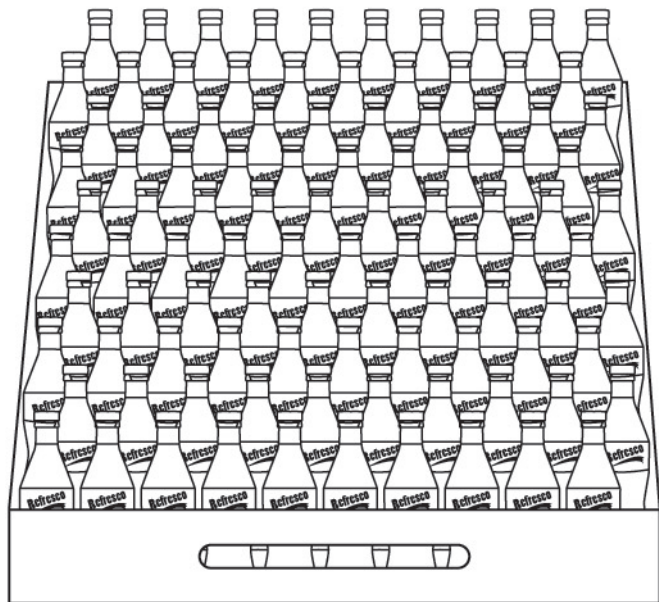
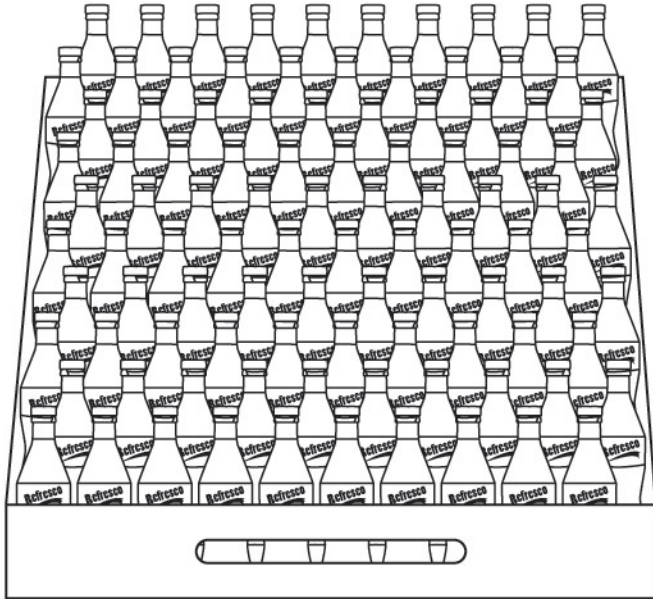

 Recortable 1.

Nivel 2

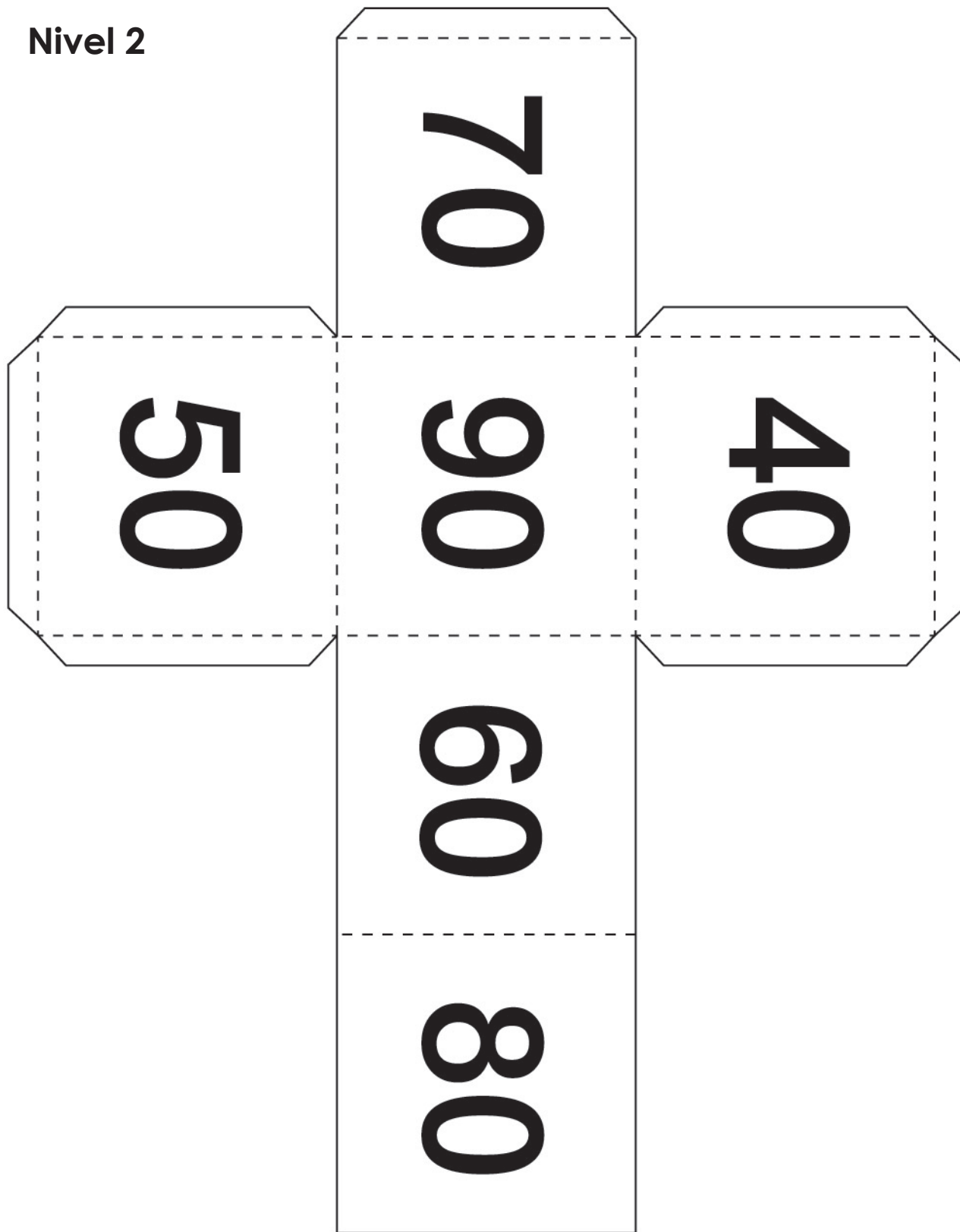

 Recortable 1.

Nivel 1

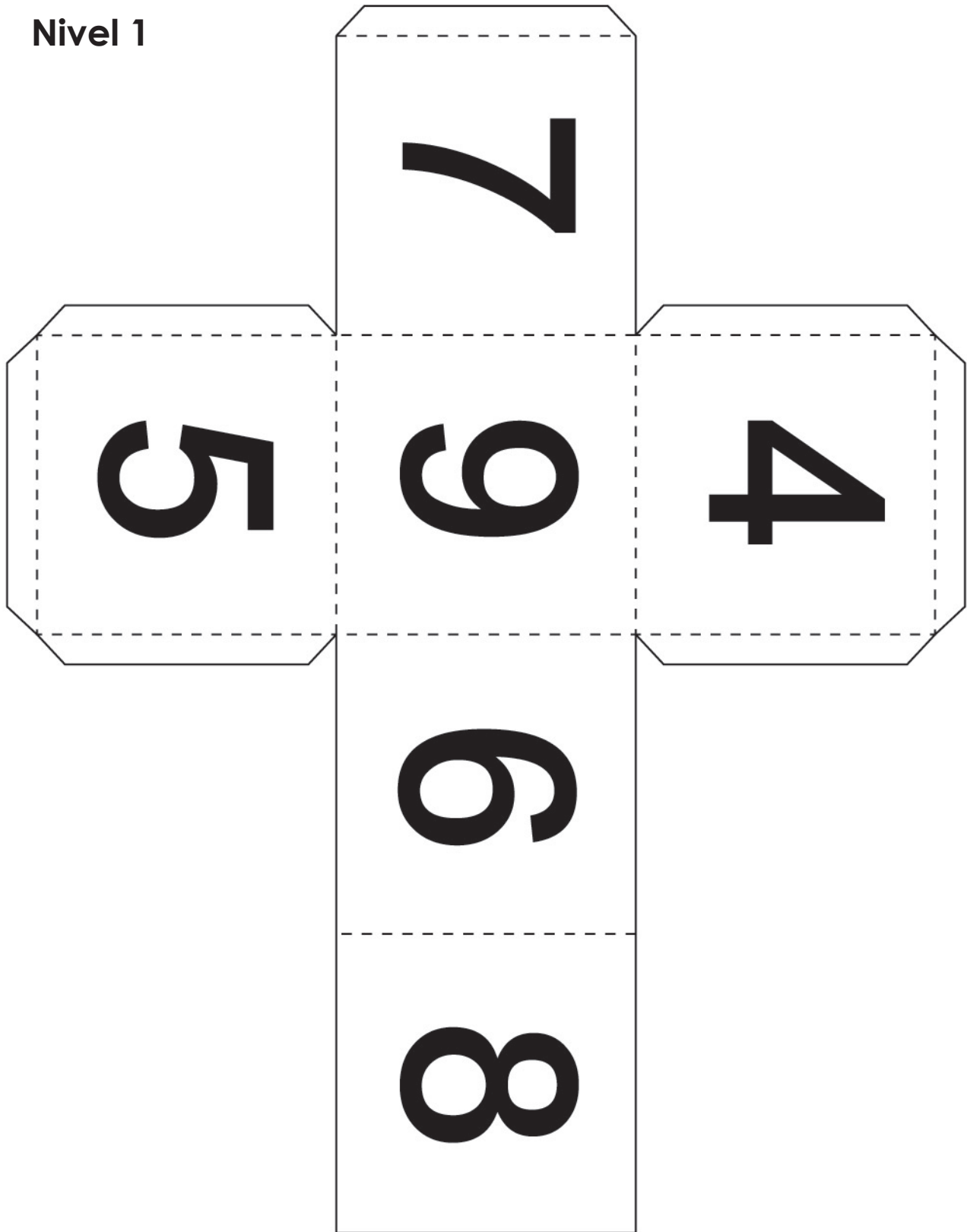

 Recortable 2.

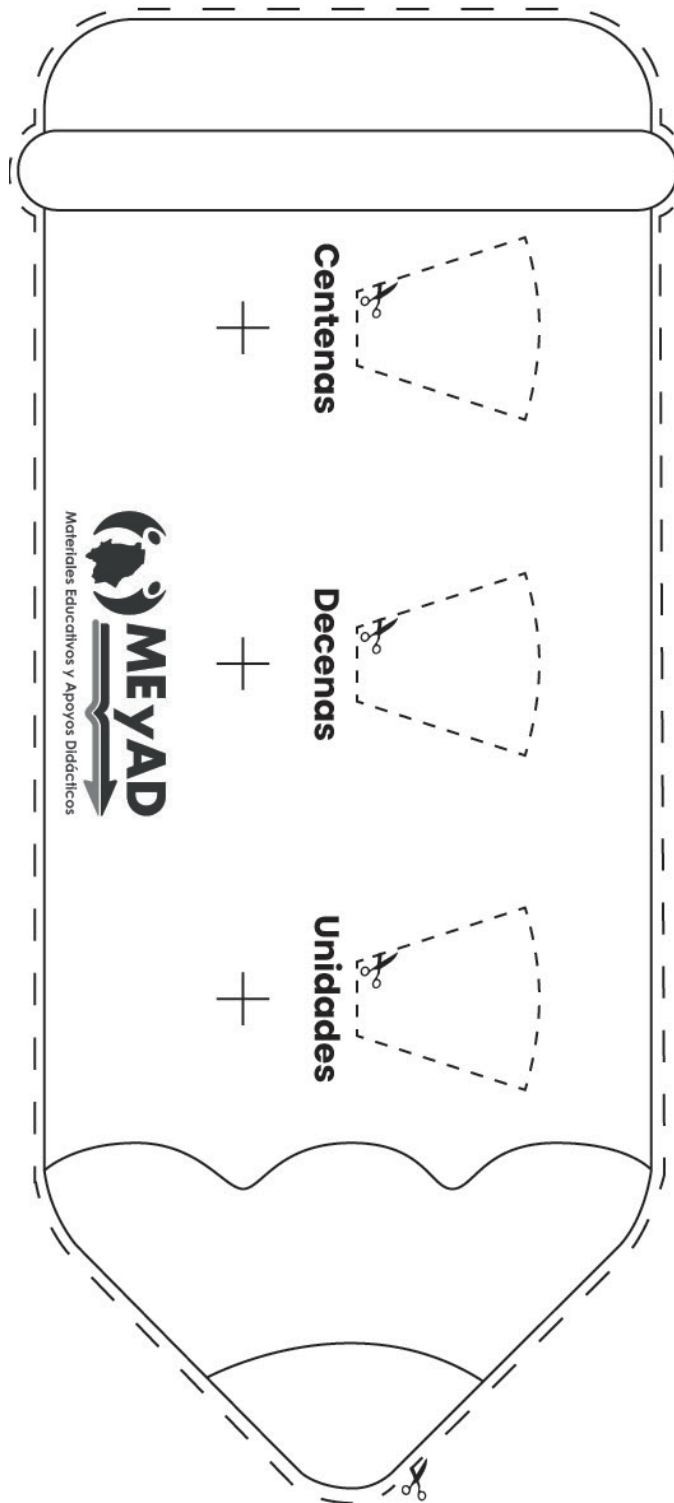

X poner una chincheta para girar.



Recorta por la orilla punteada y el recuadro punteado.

 Recortable 2.

Con una chincheta coloca el círculo donde tiene la cruz con la cruz que tiene el odómetro.

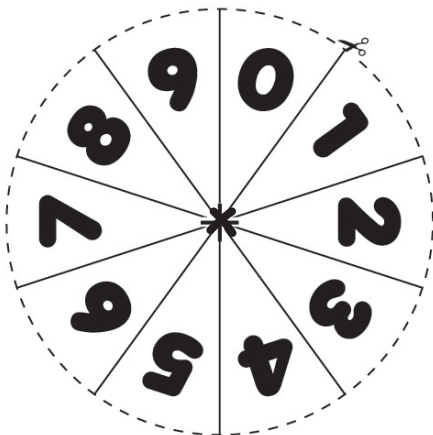
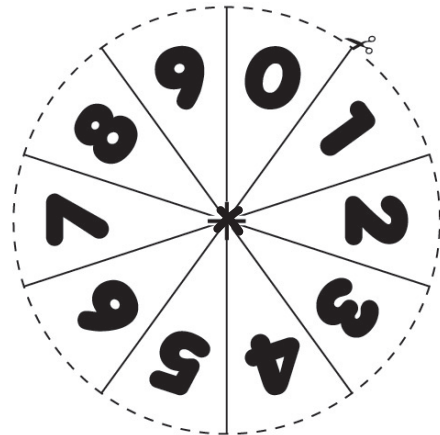
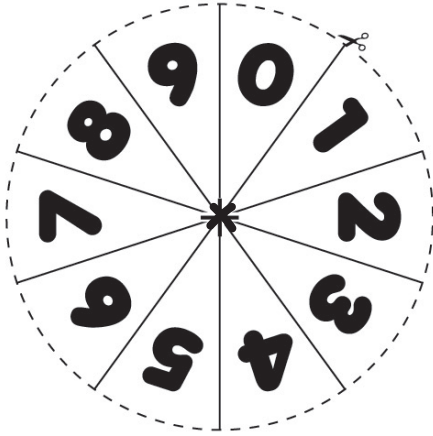

 Recortable 3.



 Recortable 3.

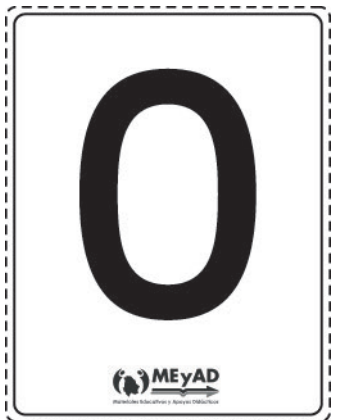

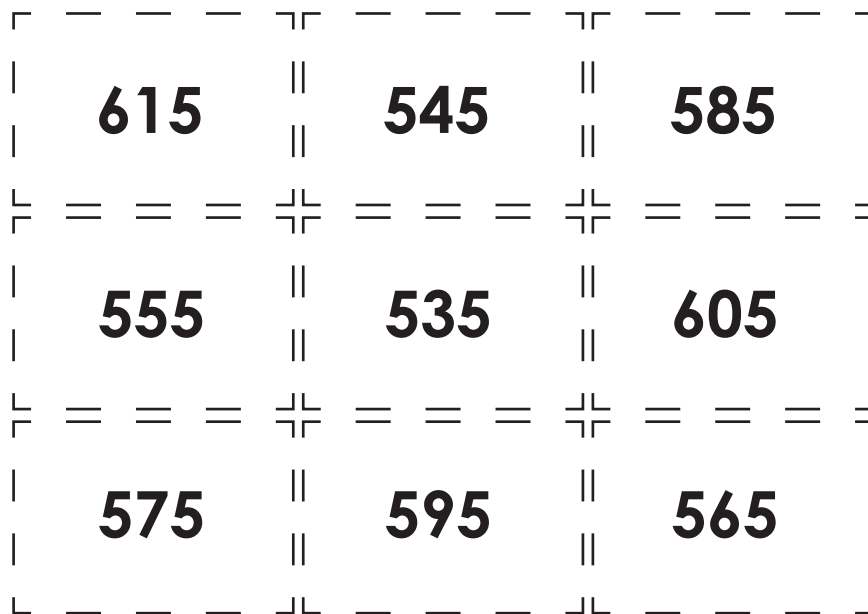
 Recortable 4.

 Recortable 5.



 Recortable 6.

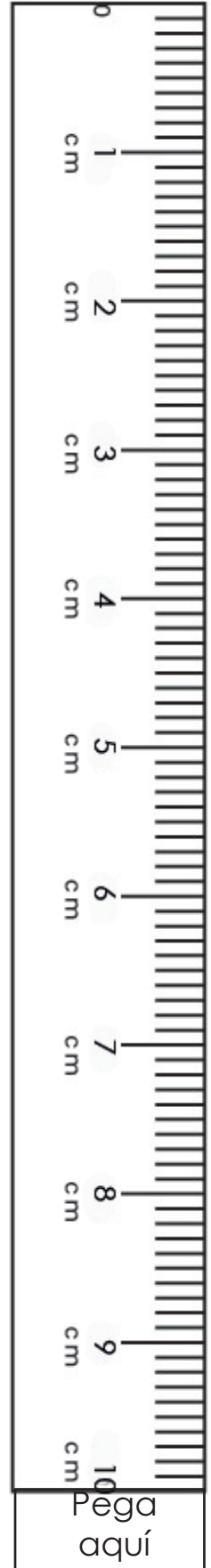
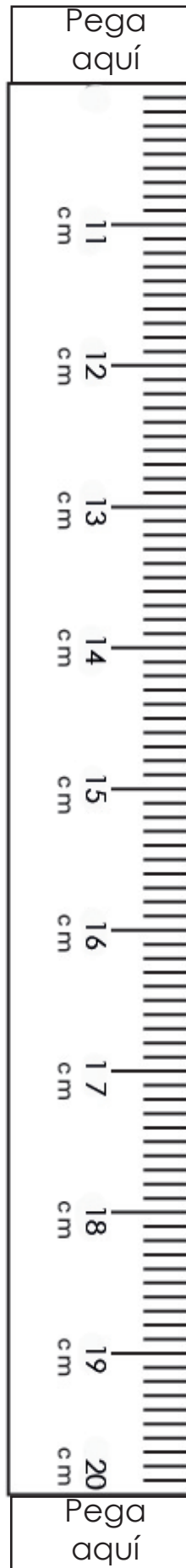

 Recortable 6.

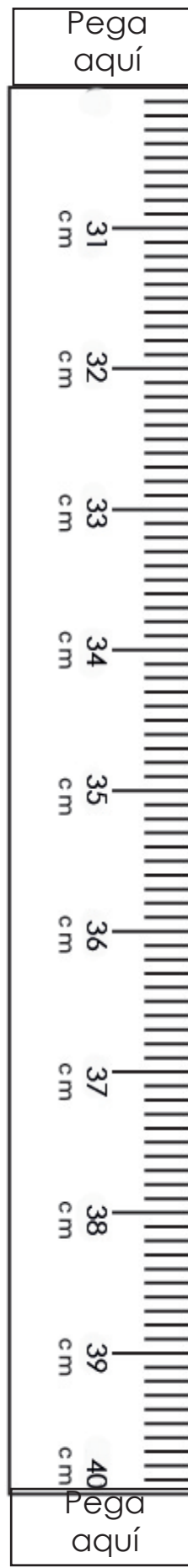

 Recortable A

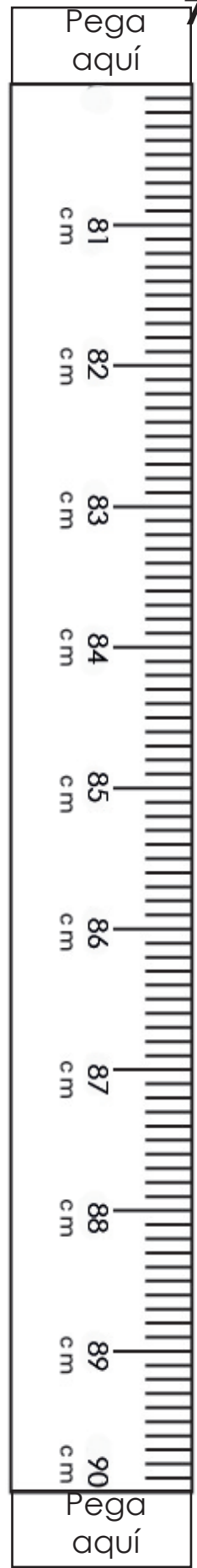
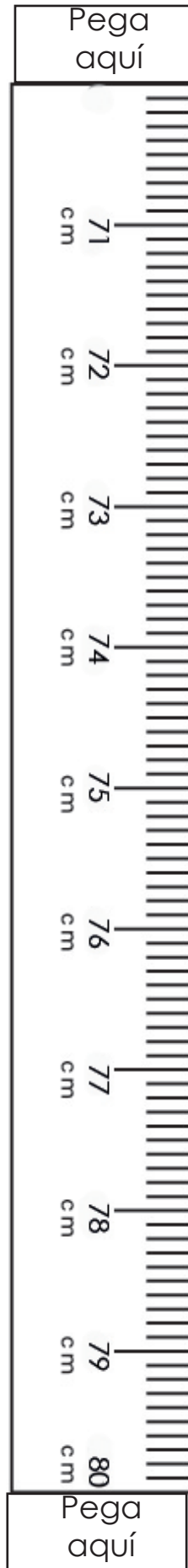

 Recortable 6.

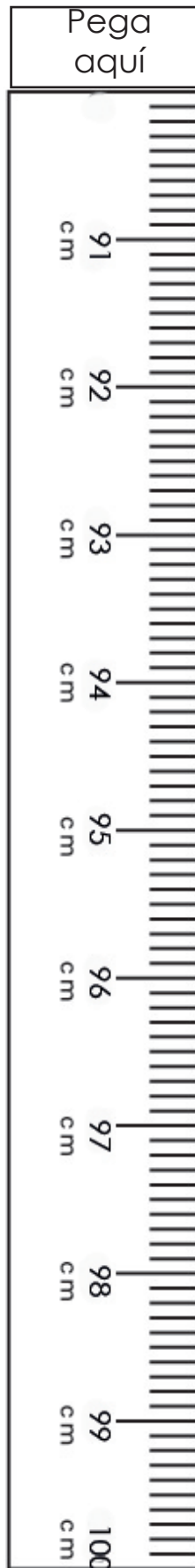



Recortable 7.

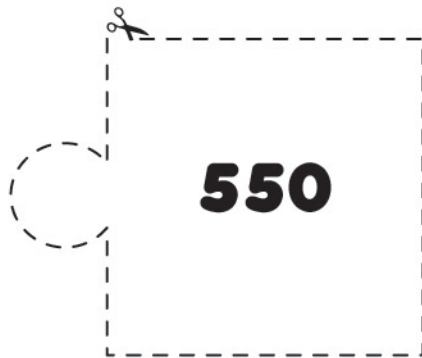
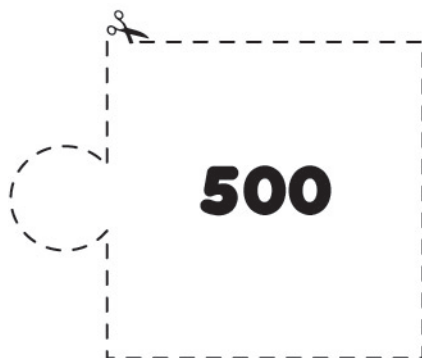
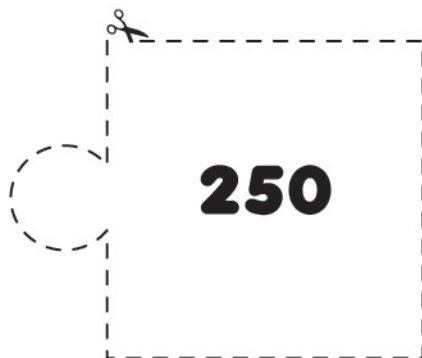
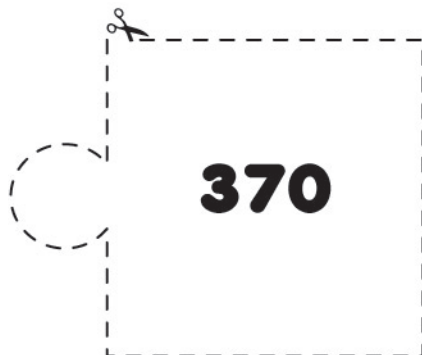

 Recortable 8.

 Recortable 9.

3

5

6

8

6

10

12

16

9

15

18

24

12

20

24

32

15

25

30

40

18

30

36

48

21

35

42

56

24

40

48

64

14

28

72

 Recortable 10.

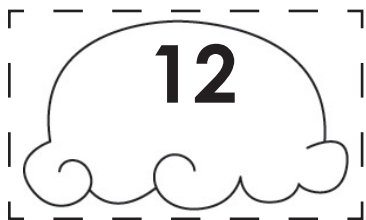
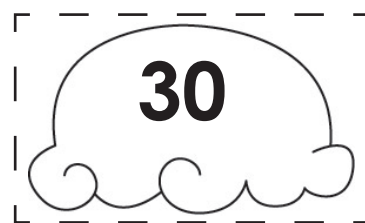
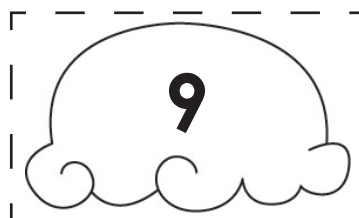
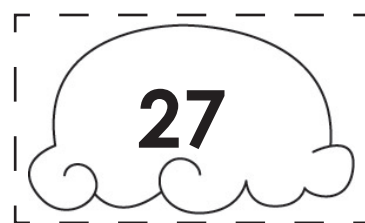
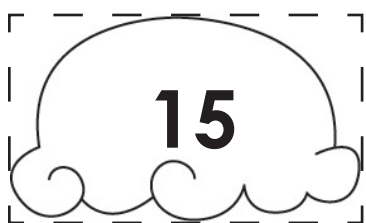
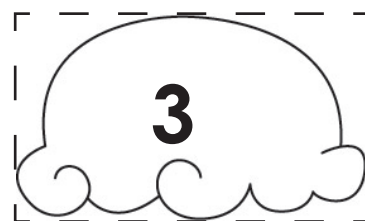

APRENDIZAJE ESPERADO: Describe cambios y permanencias en los juegos, las actividades recreativas y los sitios donde se realizan.

Aprendiendo

 Utiliza el recortable 1 y juega al dominó con un compañero.

Instrucciones.

1. Colorea las imágenes.
2. Recorta el dominó y pégalo en un cartón resistente.
3. Pueden jugar a partir de 2 participantes.
4. Decidan quién inicia el juego.
5. Lo puedes jugar juntando las palabras o actividades que sean iguales.

De las imágenes del dominó:

¿Cuáles actividades puedes hacer al aire libre?

¿Cuáles actividades conocías?

¡Qué divertido!

 Colorea el dibujo y el recortable 2.

 Utiliza el recortable 2 para que armes el dibujo en tercera dimensión.



Armando diversiones

 Utiliza el recortable 3 de las piezas del rompecabezas, ármalo y pégalo aquí.

¿Qué imagen se formó? _____

¿Dónde están jugando las niñas y niños? _____

¿Qué entiendes por actividad al aire libre? _____

APRENDIZAJE ESPERADO: Reconoce una actividad recreativa de antes.

Diversiones de antes

A Resuelve el siguiente crucigrama de juegos de antes.

Horizontales

1. Tiene una cuerda y gira en el suelo.
3. Se juega con una pelota pequeña y piezas en forma de estrellas.
4. Son fichas en forma de rectángulo con puntos.
6. Juguete de madera unido por una cuerda, un palo y una pieza en forma de barril que hay que juntar.

Verticales

2. Vuela con el viento y lo detienes con una cuerda delgada desde el suelo.
5. Son pequeñas bolitas que se hacen chocar entre ellas con ayuda de los dedos de tus manos.

Los juegos de ayer

✓ Encuentra y marca las 5 diferencias entre las imágenes.



Escribe aquí las diferencias que encontraste.

Que son: _____

APRENDIZAJE ESPERADO: Compara características de diferentes lugares y representa trayectos cotidianos con el uso del croquis y símbolos propios.

Actividades diferentes

 Encuentra el símbolo con la palabra que corresponde en el laberinto. Recuerda que no puedes pasar por los caminos tapados.

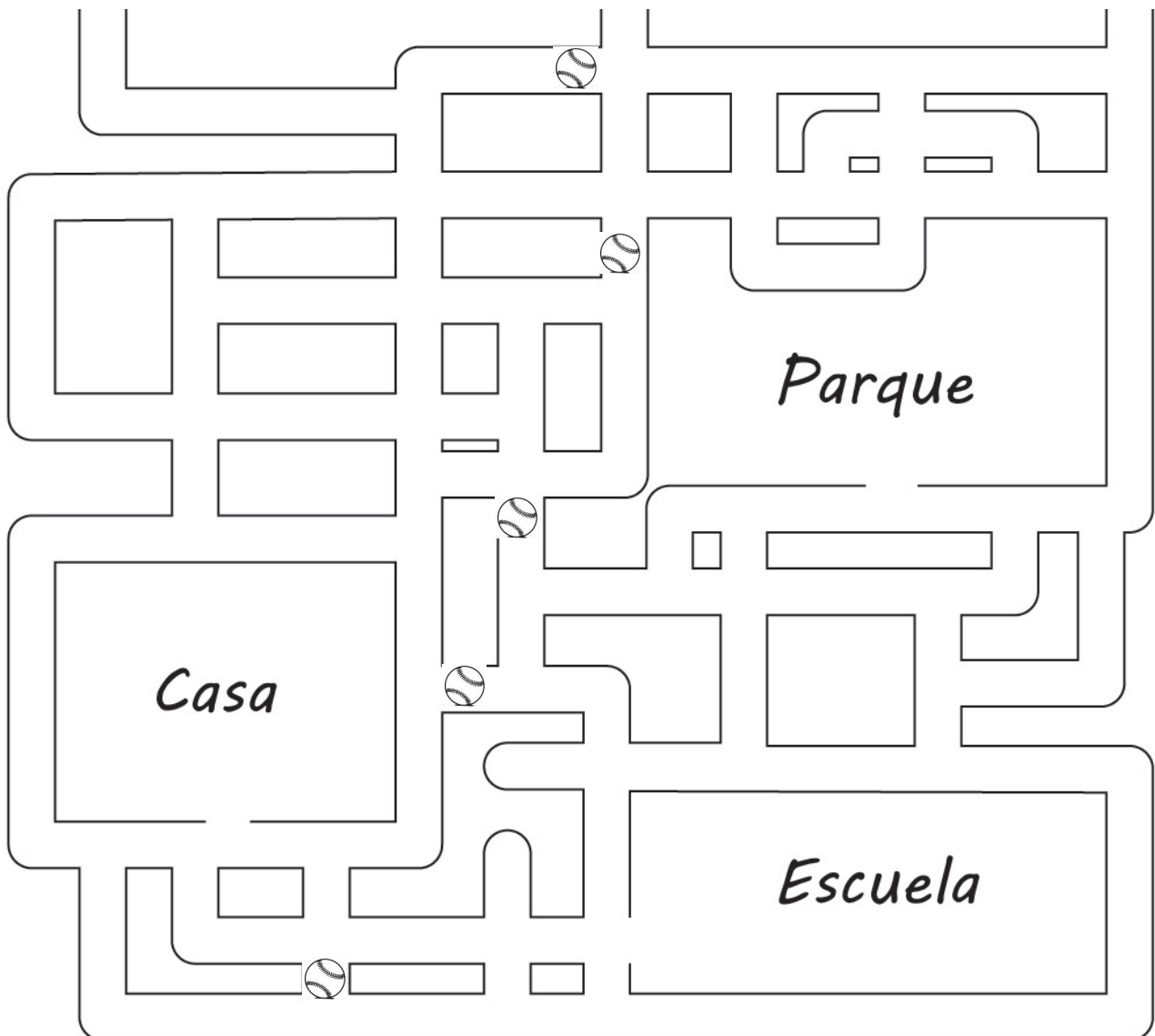

Disfrutando el paseo

👁️👁️ Observa el dibujo y contesta lo que se te pide.

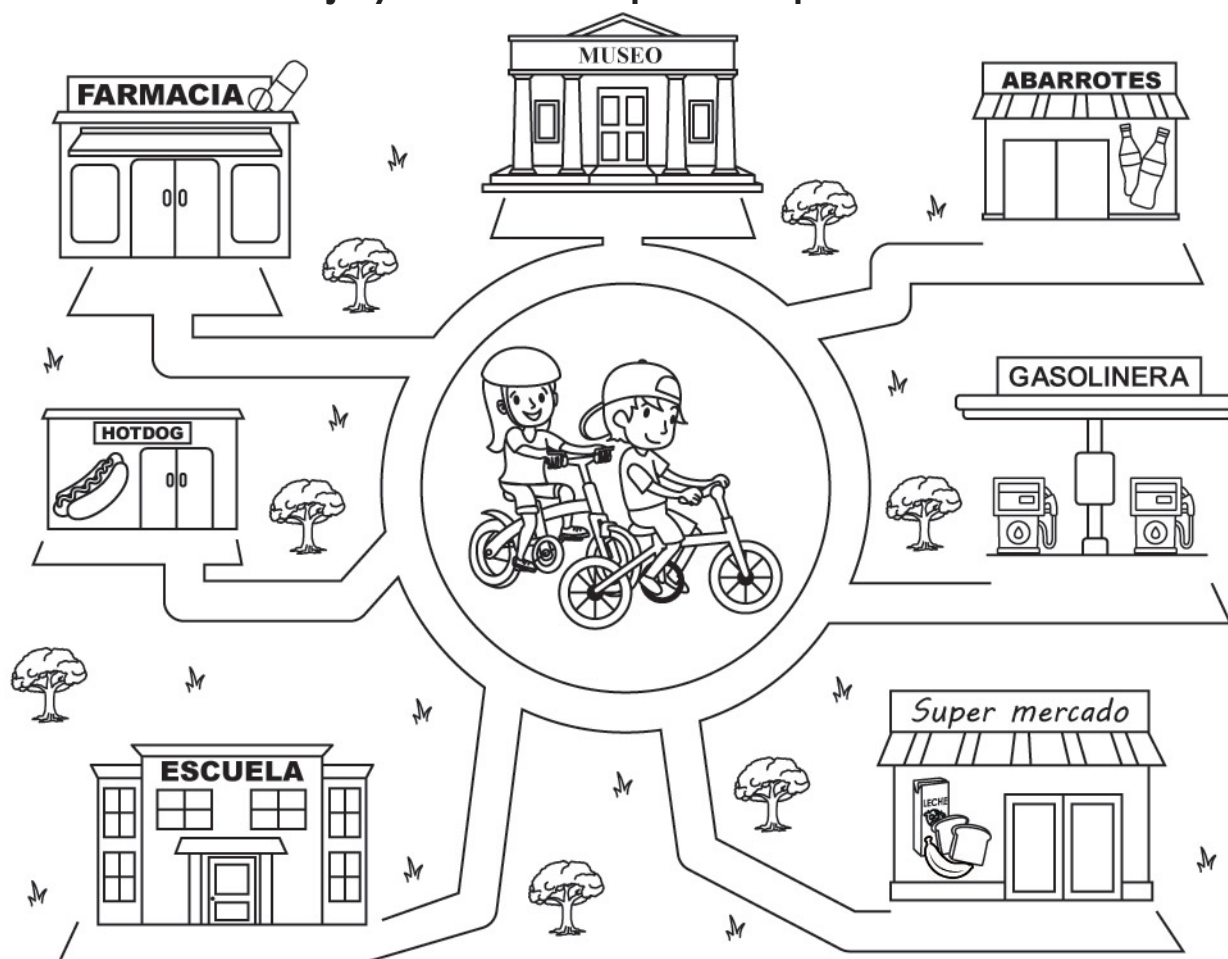

Miguel y Ana hicieron una lista de lugares a recorrer.

¿Si están en la farmacia y van a la gasolinería por qué lugares pasan?

¿Si están en la escuela que les queda más cerca, la tienda o el supermercado?

Si van del museo a los hot dog, ¿cuál lugar pasan?

APRENDIZAJE ESPERADO: Reconoce los órganos de los sentidos, su función y practica acciones para su cuidado.

¿Qué huelo?

 Utiliza el recortable 4 y pega las tarjetas que contienen imágenes en donde utilizas el sentido del olfato.

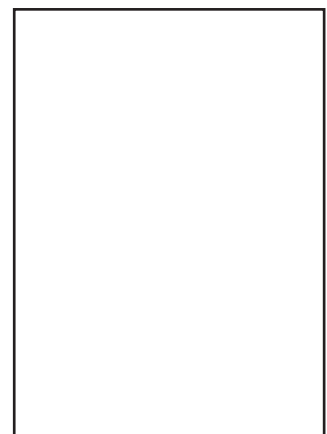
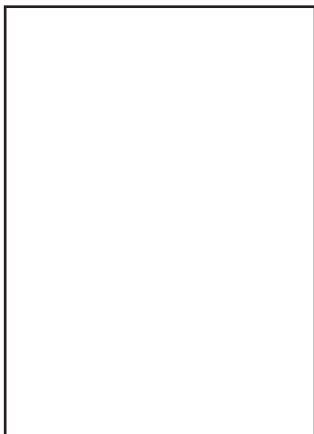
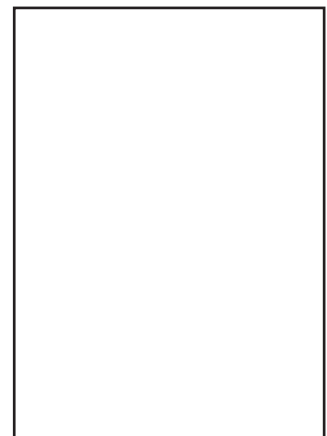
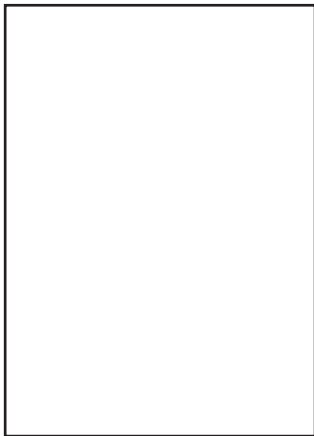

Mis emociones

 Utiliza el recortable 5 y pega la cara del niño con el olor que percibe, agradable o desagradable.

Pega aquí

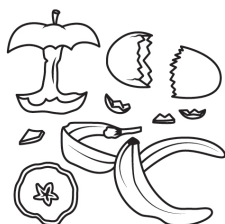

Pega aquí



Pega aquí

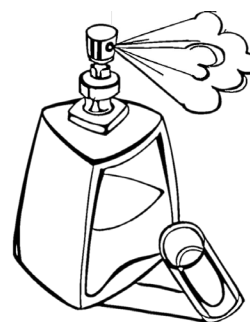

Pega aquí

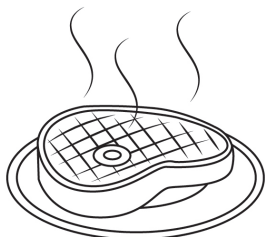

Pega aquí



Pega aquí



Pega aquí



Pega aquí



Pega aquí



APRENDIZAJE ESPERADO: Distingue formas para el cuidado del sentido del gusto y olfato.

A cuidarnos

 Utiliza el recortable 6 y coloca las imágenes en las bolsitas donde correspondan.

**Cuidados
del
gusto**

**Cuidados
del
olfato**

Me gusta, no me gusta

A  Escribe en las líneas las palabras dulce, salado o amargo, según sea el caso

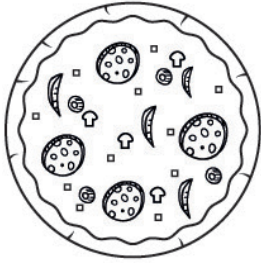

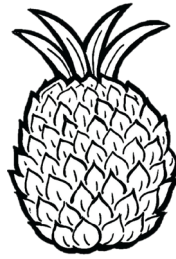

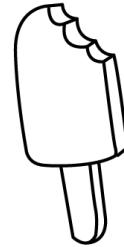

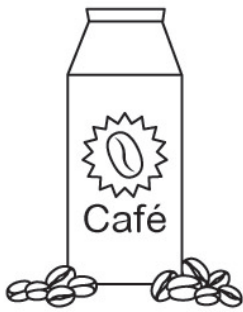





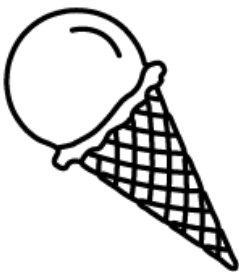



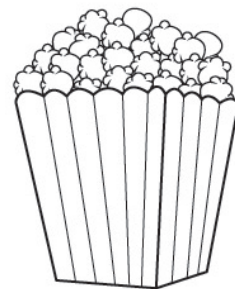

APRENDIZAJE ESPERADO: Distingue sólidos, líquidos y gases en el entorno.

Paletas de hielo

A Con la siguiente receta elabora paletas de hielo.

Necesitas
la ayuda
de un
adulto.



Ingredientes:

2 tazas de agua hirviendo
1 paquete de gelatina sabor limón
4 fresas rebanadas
1/2 sobre de polvo para hacer limonada

Hagámoslo:

Mezcla la gelatina en un tazón con el agua hirviendo revuélvelo y agrega el polvo de la limonada. Coloca la fresa en moldes para paletas y ponles palitos de madera. Por último congela las paletas durante tres horas.

¿En qué estado estaban las paletas antes de meterlas al congelador ?

¿Cómo se llama al estado en el que se encuentran las paletas?



Cocinando y aprendiendo de elementos con gas

 Estas son las formas en que podemos en que podemos observar el estado gaseoso en nuestras vidas, búscalas y encierra las palabras en la sopa de letras.

GAS

HUMO

NUBES

HELIO

NIEBLA

VAPOR

N	V	A	P	O	R	X
N	I	E	B	L	A	R
I	K	H	U	M	O	Z
A	R	V	U	R	T	M
N	Y	B	E	S	T	J
D	S	G	A	S	B	P
J	H	E	L	I	O	R

 Utiliza el recortable 7 y juega con la lotería aprendiendo sobre los elementos.

Instrucciones:

1. Con dos compañeros juega a la lotería.
2. Decidan quién dice las cartas de la lotería.
3. Gana quien llene la carta primero.

APRENDIZAJE ESPERADO: Describe cambios en la naturaleza a partir de lo que se observa en el día y la noche y durante el año.

Estaciones

 **Recorta y pega las imágenes del recortable 8 en la estación que corresponda.**

Primavera

Primavera			

Verano

Verano			

Otoño

--	--	--	--

Invierno

--	--	--	--



La estación del año

 **Juega con un compañero a la ruleta de las estaciones del recortable 9.**

Instrucciones:

1. Recorta la ruleta y la manecilla, pégalas en un material más resistente.
2. Sujeta la manecilla en el centro de la ruleta (en el círculo negro) con ayuda de una chincheta para que pueda girar.
3. Decidan quién inicia.
4. El primer jugador gira la manecilla con fuerza.
5. Observa que estación del año te tocó.

 **Utiliza las piezas del rompecabezas que tengan las características de la estación que te tocó y ármalo aquí.**

¿Cómo se llama la estación del año que pegaste y qué características tiene?

APRENDIZAJE ESPERADO: Identifica el impacto de acciones propias y de otros en el medioambiente y participa en su cuidado.

Cuidando el mundo

 Con ayuda del recortable 10 pega las imágenes de las acciones que hacemos al medioambiente donde correspondan.

**Acciones
que ayudan al medio
ambiente**

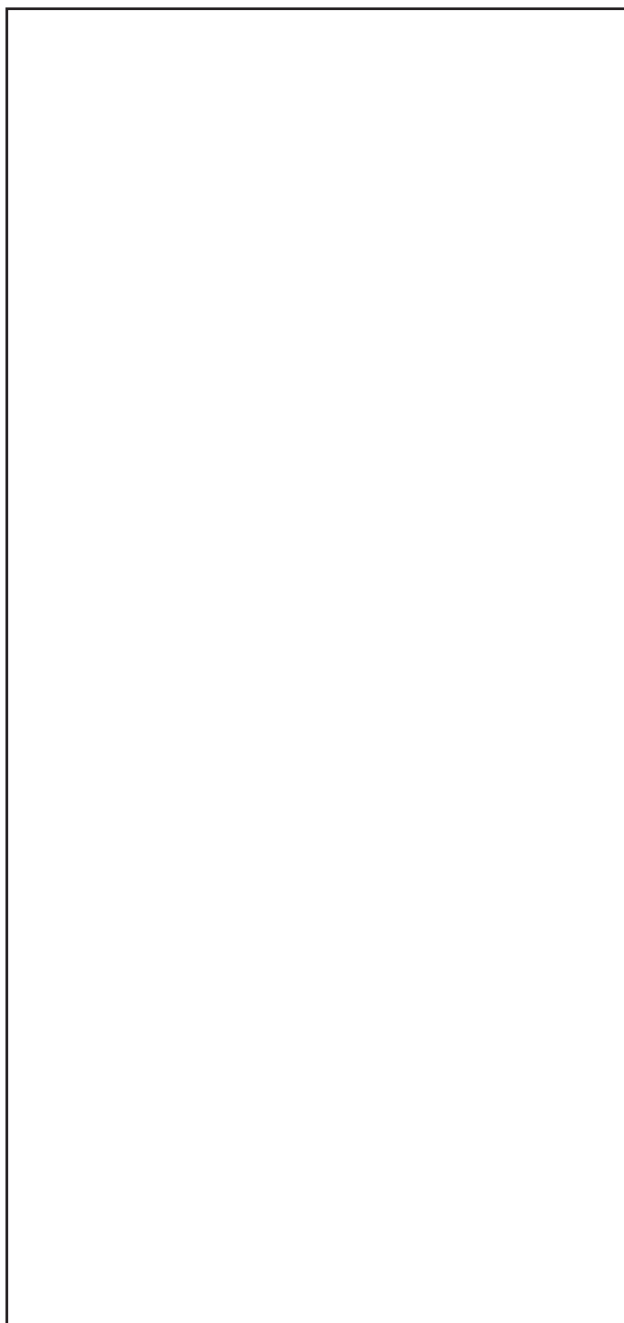

**Acciones
que dañan al medio
ambiente**

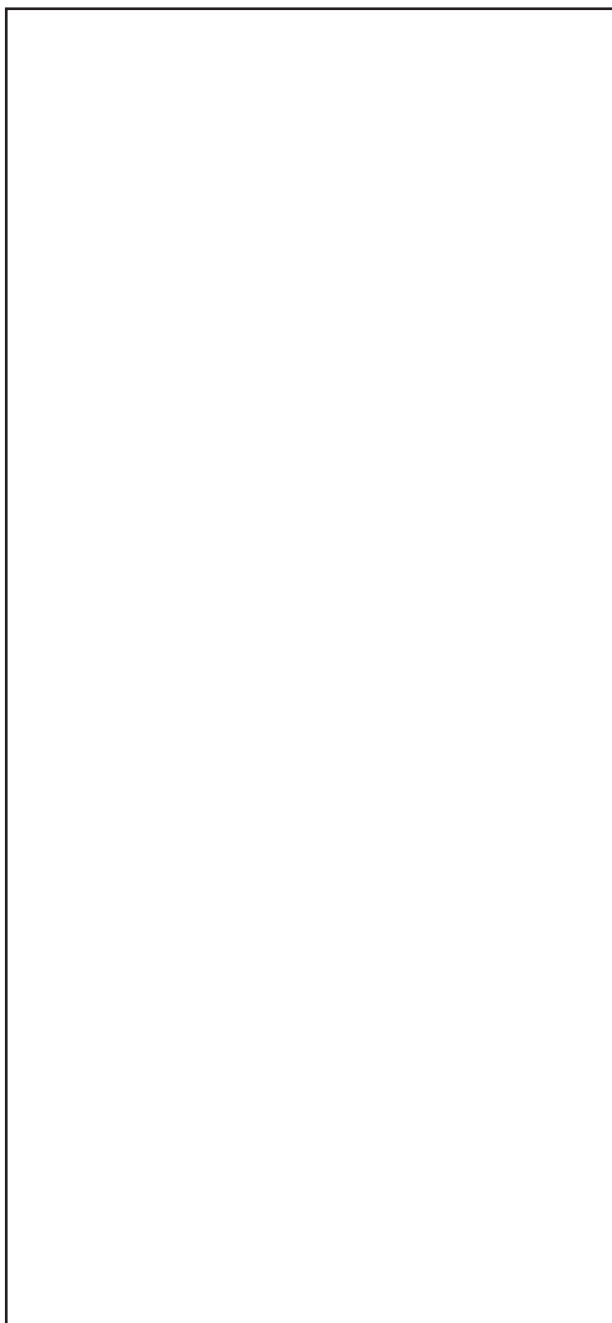

Ayudo a cuidar

 Utiliza el recortable 11 y pega los botes de reciclar.

 Recorta las imágenes y colócalas en el bote que corresponde.

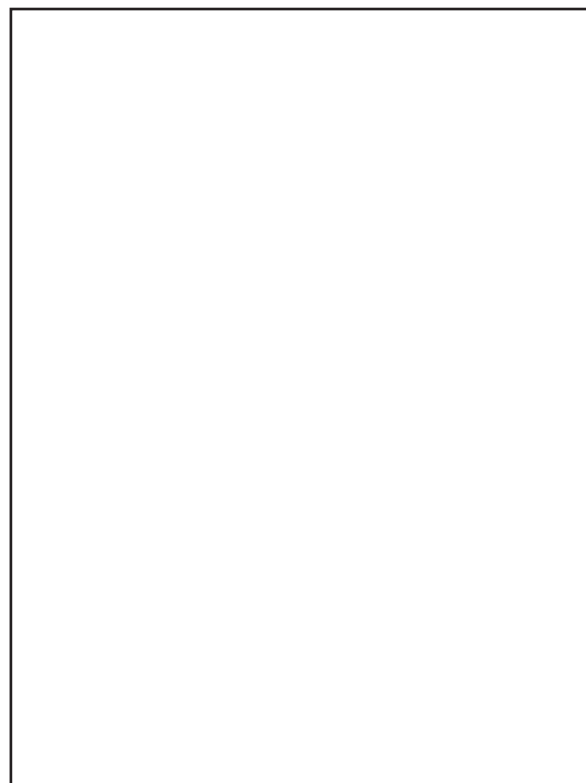
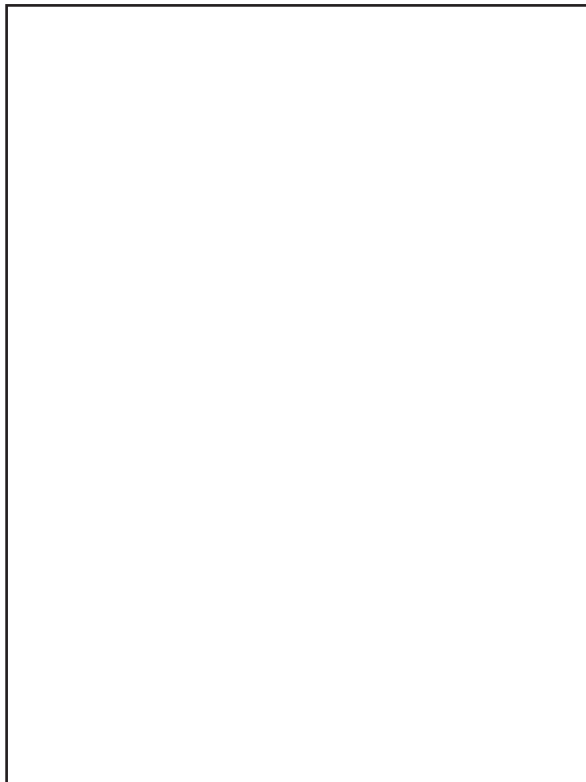

APRENDIZAJE ESPERADO: Describe costumbres, tradiciones, celebraciones y conmemoraciones del lugar donde vive y cómo han cambiado con el paso del tiempo.

¿Qué hay en el museo?

 Utiliza las imágenes del recortable 12 y coloca las que pertenecen a un museo.

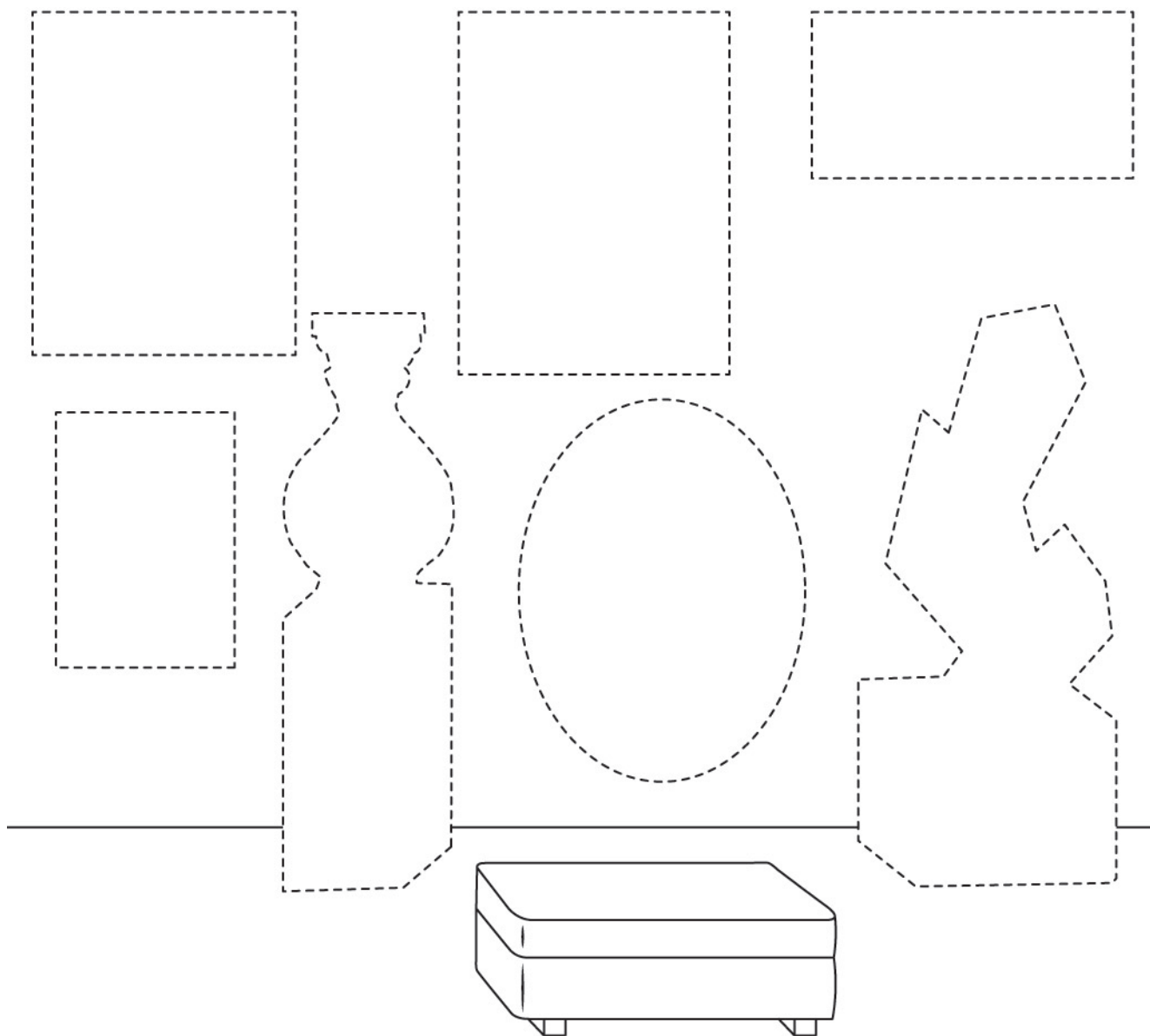

R
E
C
O
R
T
A
B
L
E
S



 Recortable 1.

niño
corriendo

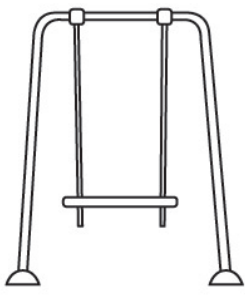

raqueta



caña de
pescar



niño
escalando



bate de
beisbol

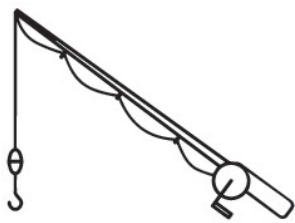

pelota
de futbol

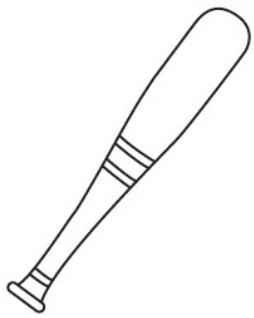

 Recortable 1.

bicicleta



columpio



papalote



pelota
básquet



patines

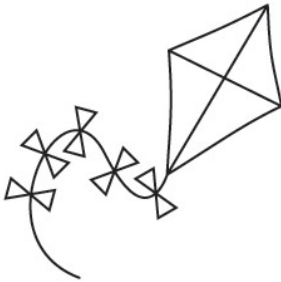

patines
para hielo



 Recortable 1.

niño
corriendo

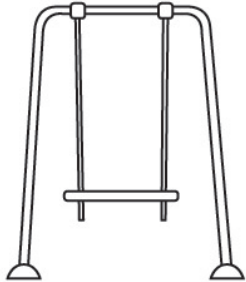

raqueta



caña de
pescar



niño
escalando



bate de
beisbol

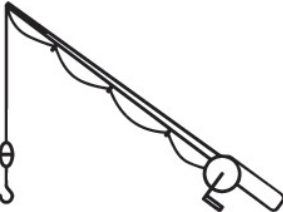

pelota
de futbol

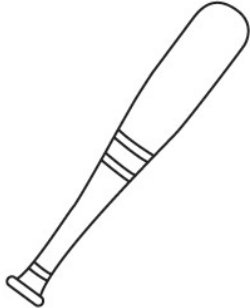

 Recortable 1.

bicicleta



columpio



papalote



pelota
básquet



patines

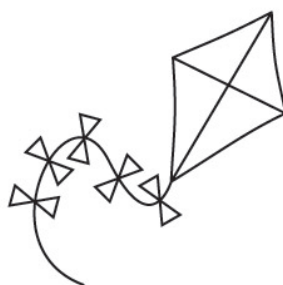

patines
para hielo





Recortable 2.

Figuras para cuadro tercera dimensión



Recorta las tiras y doblalas para que pegues en un extremo la figura y en el otro extremo en el dibujo.

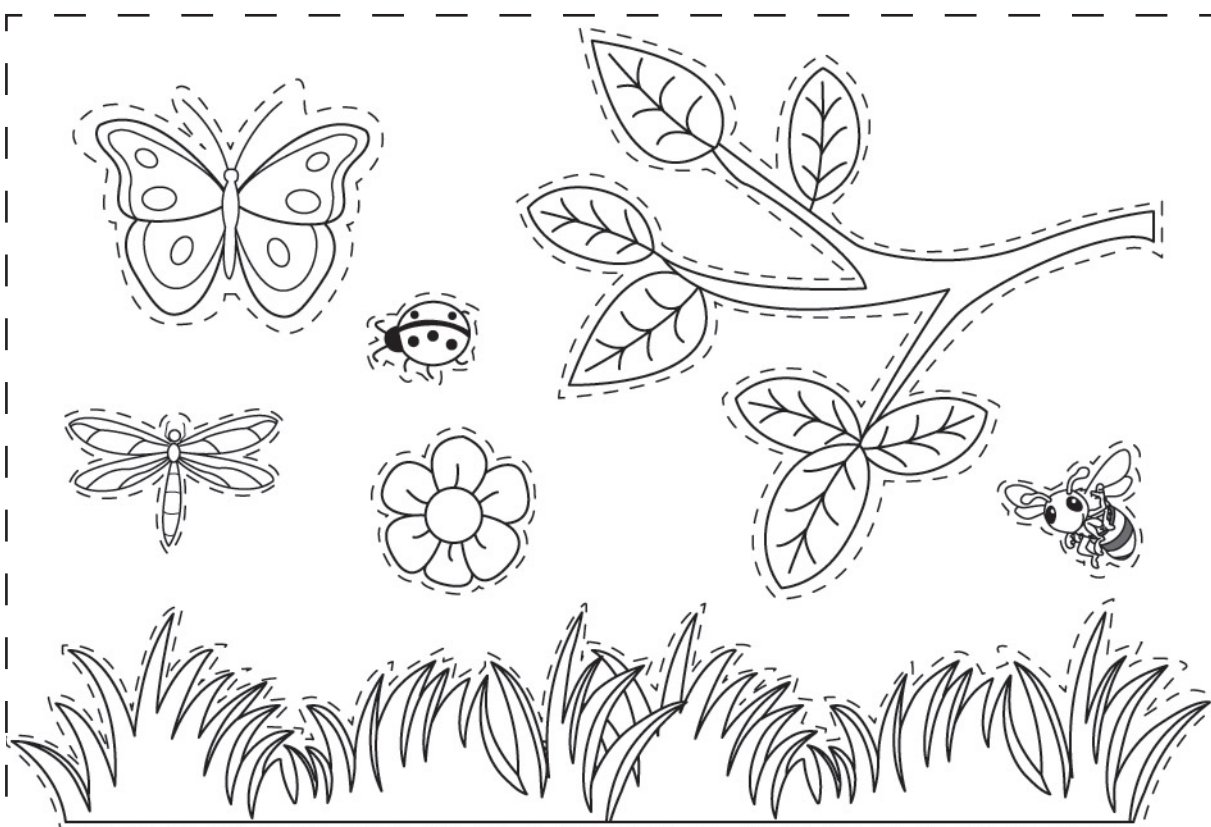

Dobla las tiras
así.

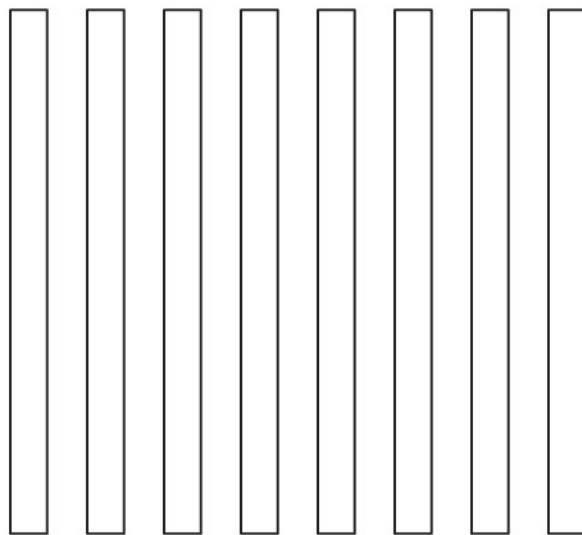

 Recortable 3. Rompecabezas

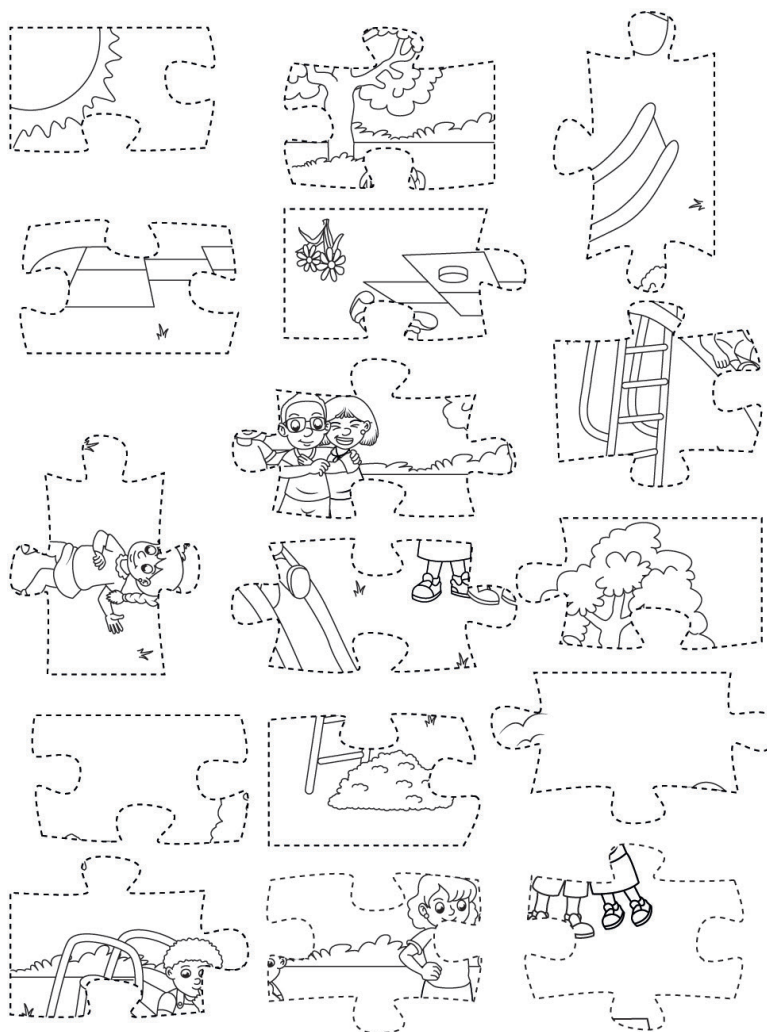

 Recortable 4.

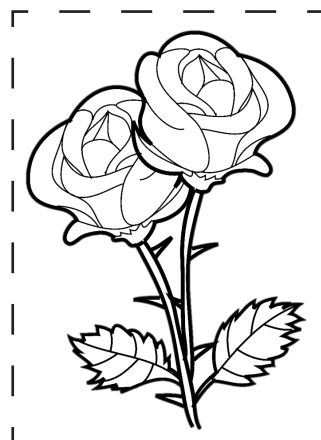
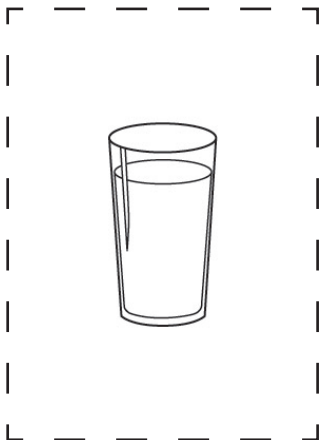
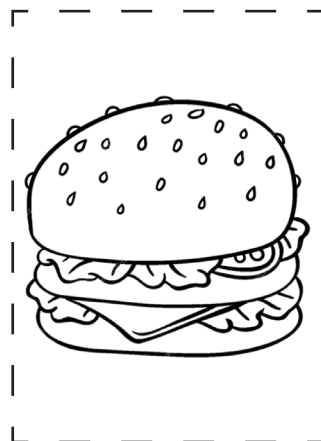
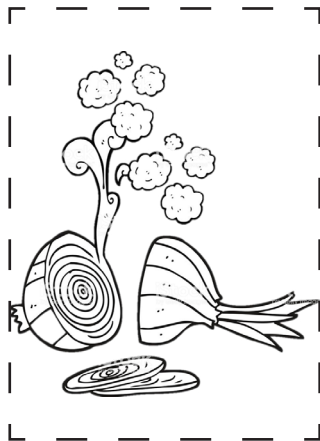
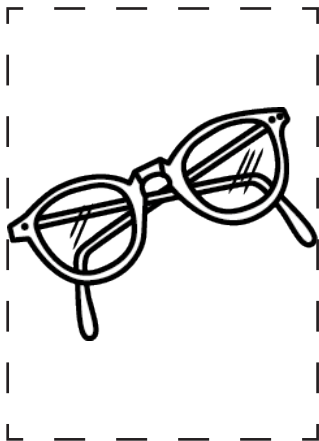
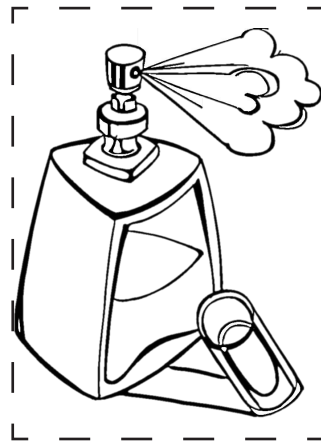
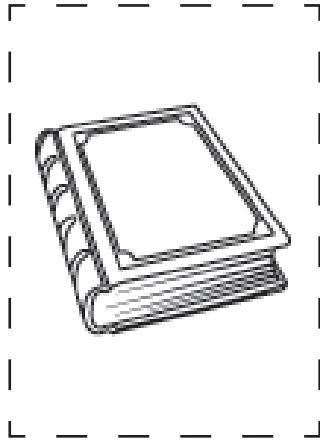
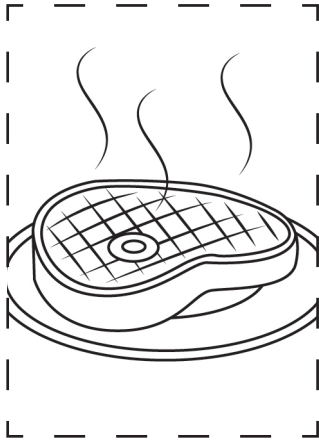

 Recortable 5.

Caras diferentes

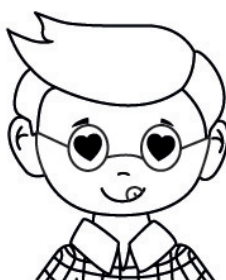



Recortable 6.

Bolsas de cuidado gusto y olfato









Recortable 6.



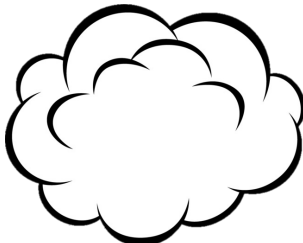

Bolsas de cuidado gusto y olfato

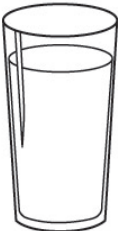

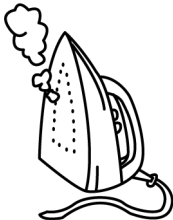
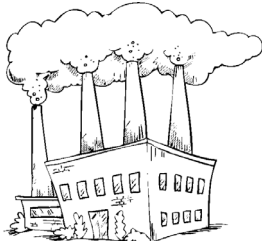

 Recortable 7.

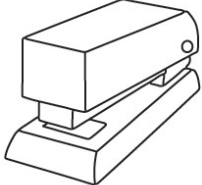
<p>Gases</p> 	<p>Gases</p> 
<p>Sólido</p> 	<p>Líquido</p> 
<p>Sólido</p> 	<p>Líquido</p> 

 Recortable 7.

<p>Gases</p> 	<p>Gases</p> 
<p>Sólido</p> 	<p>Líquido</p> 
<p>Sólido</p> 	<p>Líquido</p> 

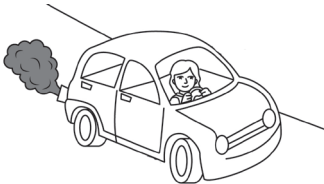
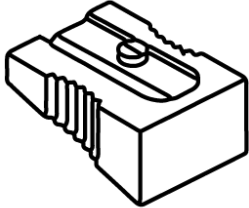
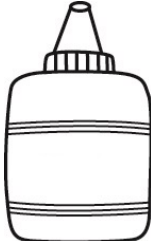
 Recortable 7. Lotería

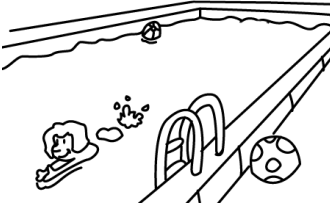
<p>Gases</p> 	<p>Gases</p> 
<p>Sólido</p> 	<p>Líquido</p> 
<p>Sólido</p> 	<p>Líquido</p> 

La pelota



El agua



El vapor



 Recortable 7. Lotería

La silla



El aceite



La plancha



La grapadora

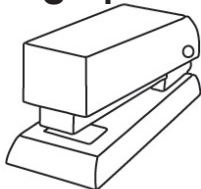

Las burbujas



El humo

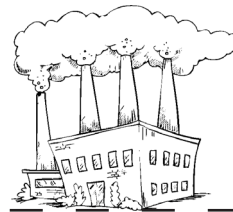

El lápiz



La leche



La nube

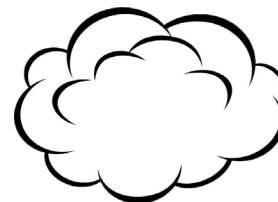

El sacapuntas

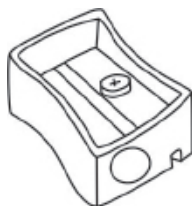

El resistol



La fogata



Las tijeras

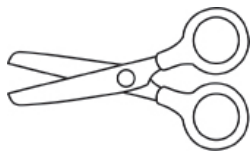

La piscina

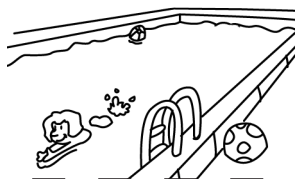

El smog



✂ Recortable 8.

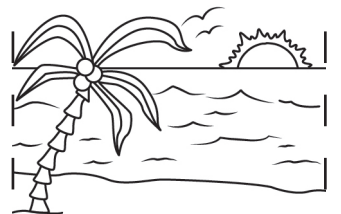
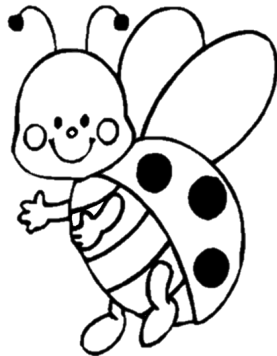
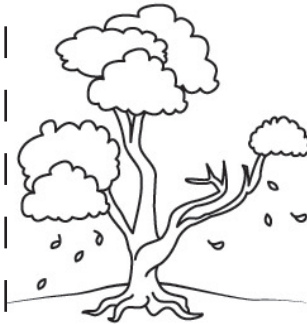
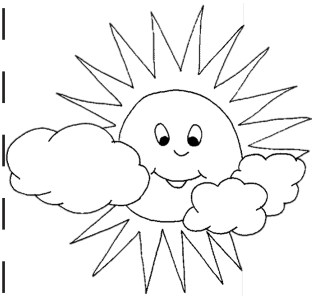
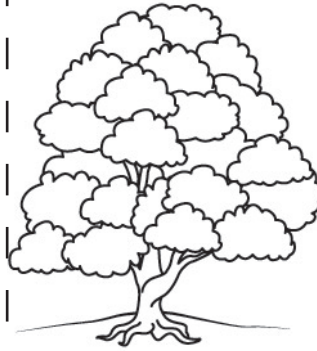

 Recortable 9.

Instrucciones: Recorta el círculo y la manecilla de las estaciones y pégalo en cartulina.
Sujeta la manecilla y el círculo con una chincheta para que pueda girar.

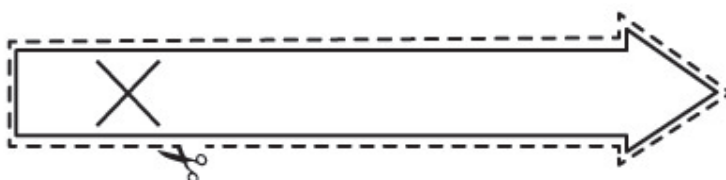
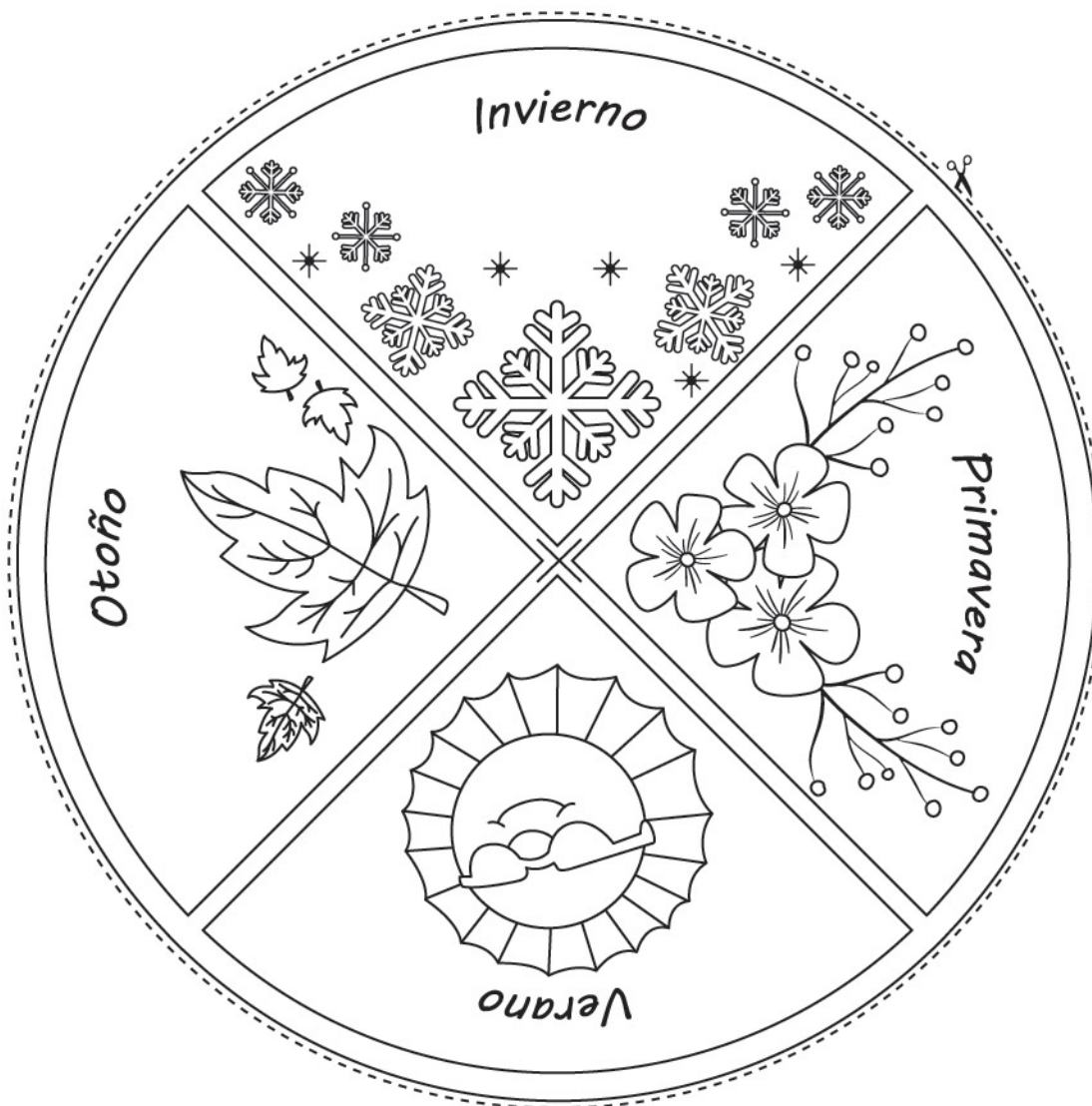

 Recortable 9. Rompecabezas de estaciones del año

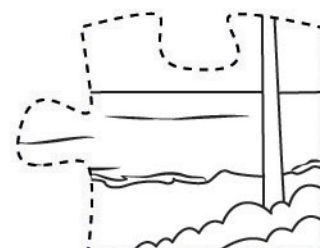
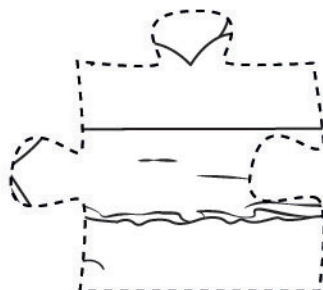
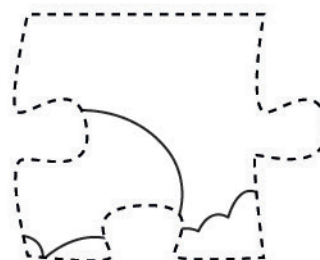
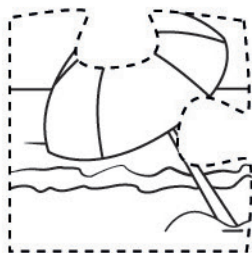
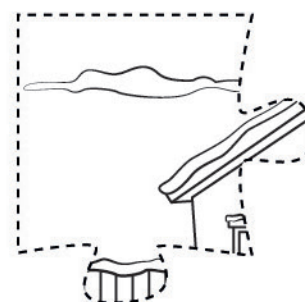
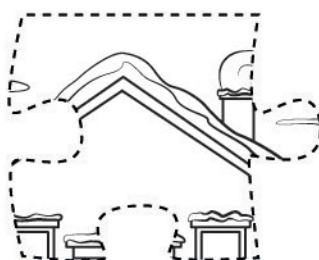
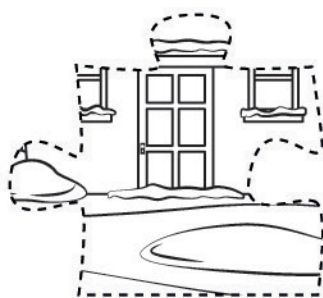
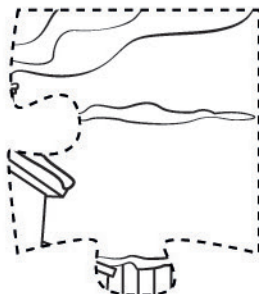

 **Recortable 9. Rompecabezas de estaciones del año**

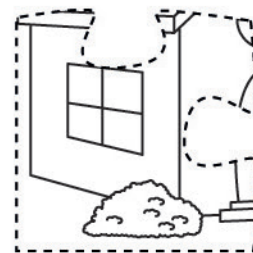
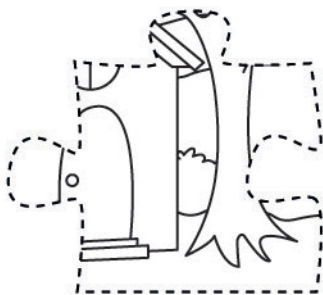
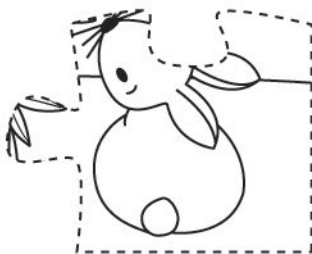
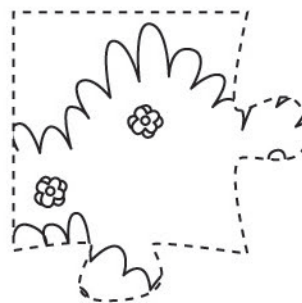

 Recortable 10.

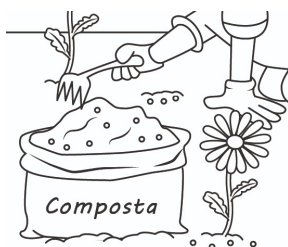
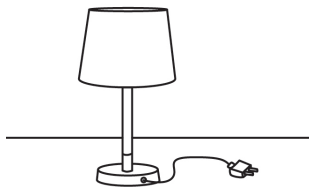
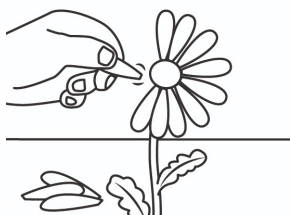
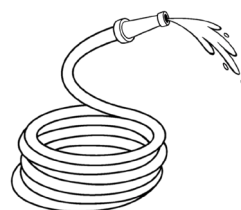
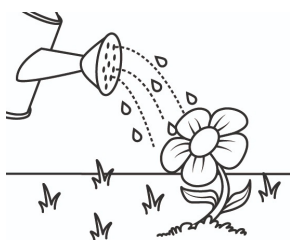
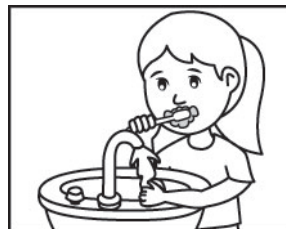
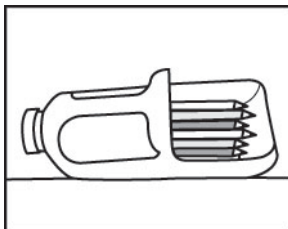

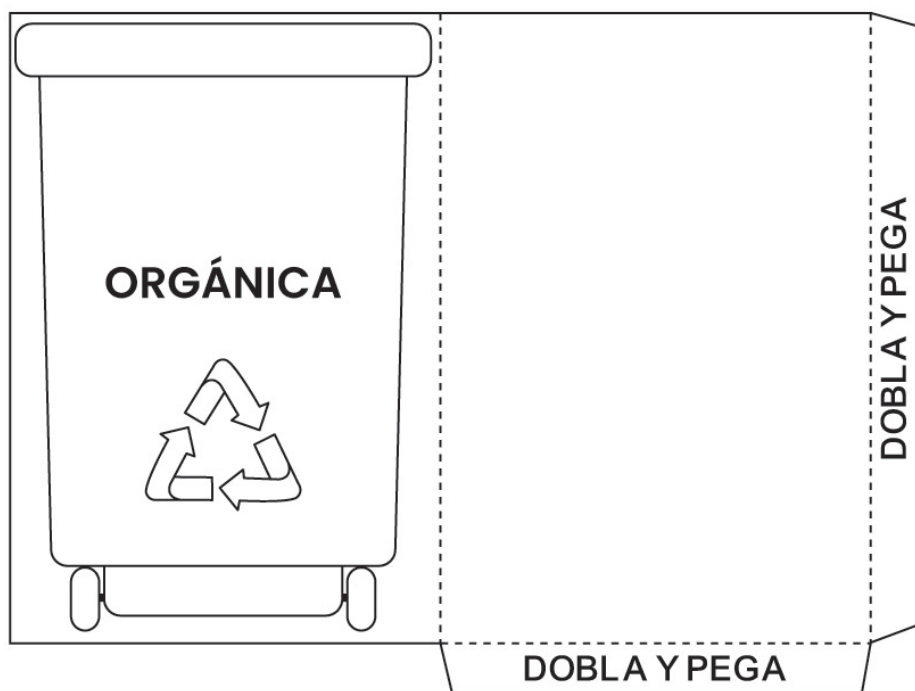
 Recortable 11.

Colorea de verde el bote orgánico.

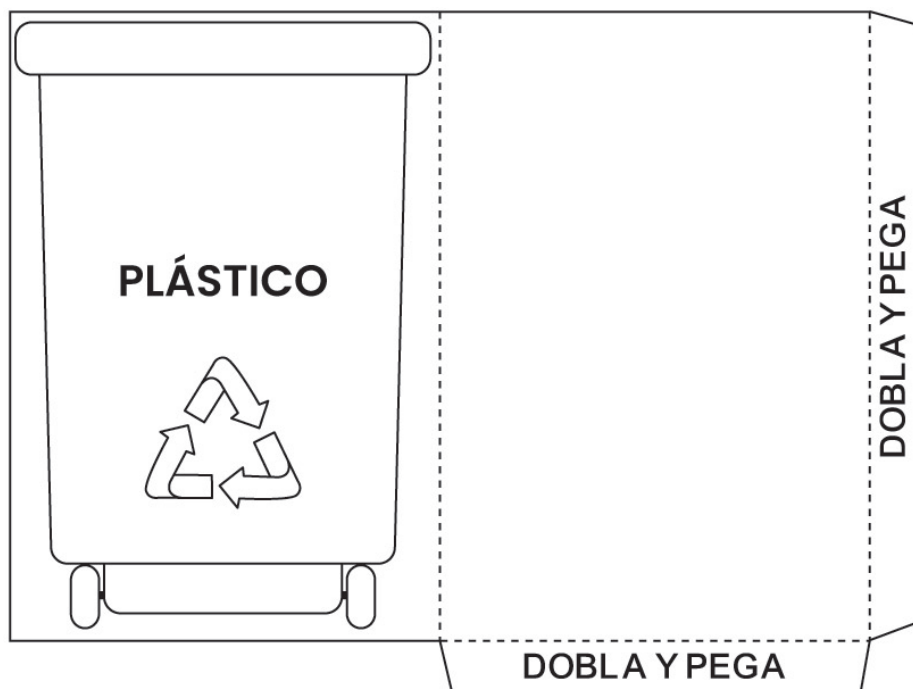

Colorea de amarillo el bote para los plásticos.

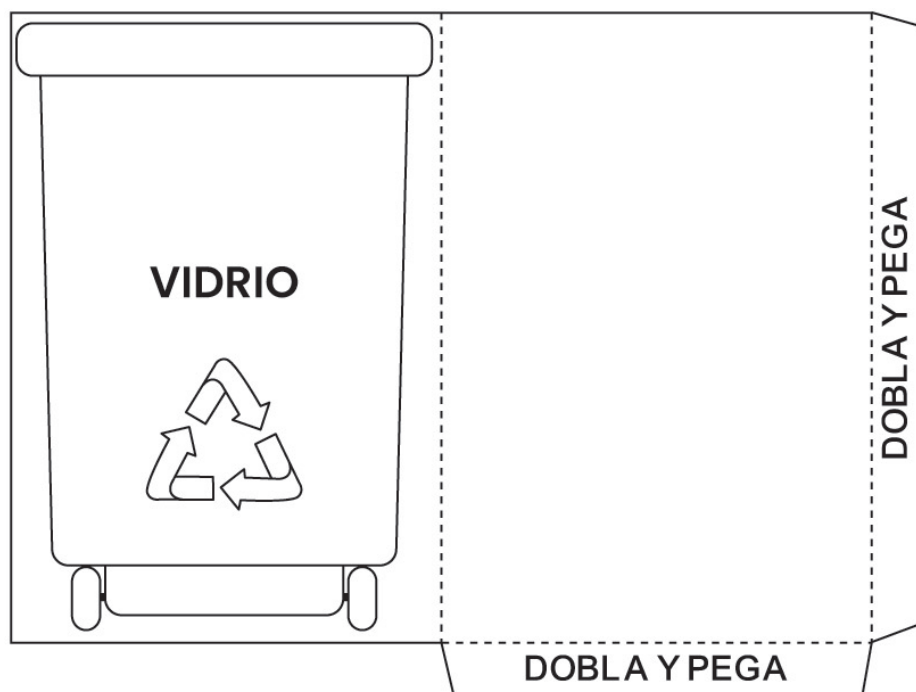
 Recortable 11.

Colorea de rojo el bote para vidrio.

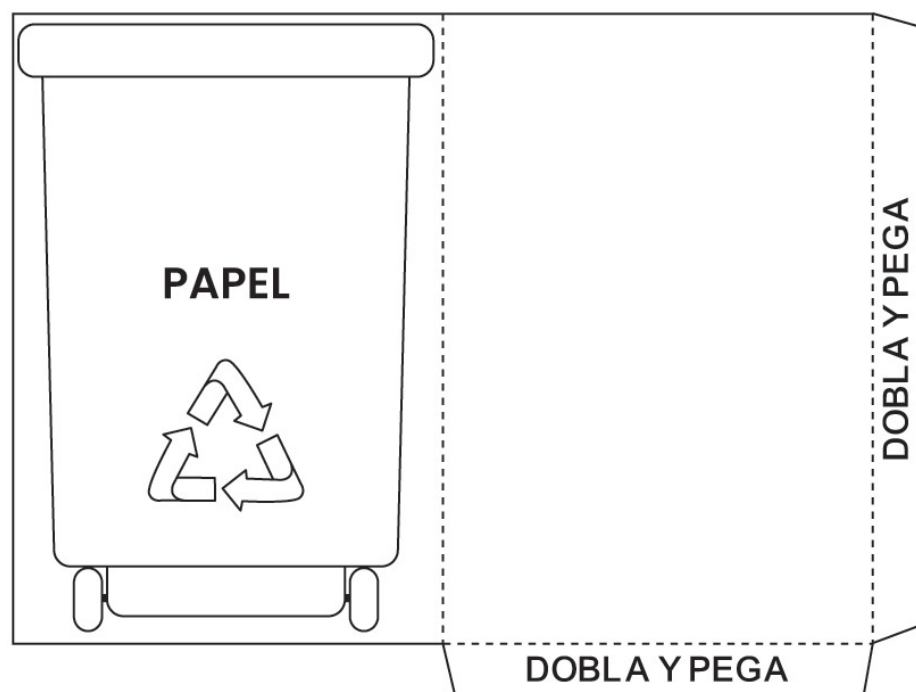

Colorea de azul el bote para el papel.

 Recortable 11.

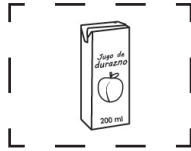
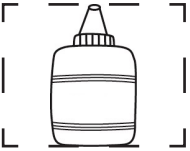
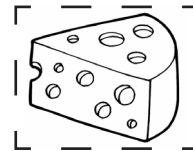
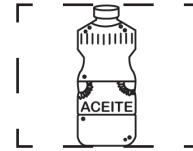

 Recortable 12.

